



UNITED STATES COAST GUARD AUXILIARY

Life Jacket Loaner Program

Standard Operating Procedures & Guidelines

15 NOV 2013



16790

NOV 22 2013

MEMORANDUM

From: F. T. BOROSS, CAPT
COMDT (CG-BSX)

A handwritten signature in blue ink, appearing to read "F. T. Boross".

Reply to LT Mark Unpingco
Attn of: (202) 372-1056

To: Distribution

Subj: LIFE JACKET LOANER PROGRAM

Ref: (a) Auxiliary Manual, COMDTINST M16790.1 (series)
(b) National Recreational Boating Safety Program Strategic Plan

1. **PURPOSE.** In accordance with reference (a) and in furtherance of reference (b), Strategic Directive #4, to increase life jacket wear rates nationwide, this promulgation letter establishes the Life Jacket Loaner Program as an authorized Auxiliary activity. Auxiliarists may be assigned to duty to support this program.
2. **ACTION.** Elected and appointed leaders and program managers at all levels of the Auxiliary organization who oversee, direct, or participate in the administration, training and activities of the Life Jacket Loaner Program are to adhere to the procedures and guidelines established in enclosure (1). Internet release authorized.
3. **DISCUSSION.** The goal of this program is to increase life jacket wear during water-based activities as well as to educate the boating public on the importance of proper use and fit. Research shows that most drowning fatalities would have been prevented if the victim had been wearing a life jacket. The Life Jacket Loaner Program promotes the availability and use of life jackets by the general public while establishing associated maintenance and record keeping standards. Included in the SOP is a waiver to reduce any liability for the Coast Guard and the Coast Guard Auxiliary.

#

Encl: (1) Life Jacket Loaner Program Standard Operating Procedures and Guidelines

Dist: ANSC, NACO, VNACO, DNACO-RBS, ANACO-CC, ANACO-RB, DIR-V

Table of Contents

- I. Purpose**
- II. Applicability**
- III. Background**
- IV. Summary of Guidance**
- V. Specific Guidance**
- VI. Recommended Guidance**
- VII. Procurement of Loaner Program Materials**
- VIII. Communications Plan and Public Education Initiatives**
- IX. Examples of Two Types of Loaner Programs**

Appendices:

- A - Potential Partnership Opportunities**
- B - Life Jacket Loaner Station Sample Inspection/Restocking Logs**
- C - Sample Letter to Borrowers for Unreturned Life Jackets**
- D - Life Jacket Loaner Program Sample Communications Plan**
- E - Sample Loaner Station Photos**
- F - Sample Life Jacket Loaner Station Design Plans**
- G – Liability Waiver Template**

I. Purpose

This document establishes the national Standard Operating Procedure for maintenance, inspection, public information, and program implementation for U.S. Coast Guard Auxiliary (Auxiliary) managed loaner life jacket stations. In addition it provides guidelines and recommendations that can be followed to aid in the design and construction of loaner stations that are installed or maintained by the Auxiliary.

II. Applicability

These guidelines apply to all Auxiliary units implementing or managing any type of life jacket loaner program.

III. Background

The life jacket loaner program provides the public with free use of life jackets on a first-come, first-served basis. Research shows that most drowning could have been prevented if a life jacket had been worn by the victim. The goals for this program are to increase life jacket wear during water-based activities as well as to educate the visiting public on the importance of proper use and fit.

Life jacket loaner stations have been successfully used since the mid-1980s by various organizations as a tool in reducing public recreation-related fatalities on their waters. Most of these stations offer various sizes of life jackets from infant to adult in limited quantities. Demand for use of the life jackets has generally exceeded the available supply. Many of the loaner stations in existence have cooperatively been installed and maintained by local partners, such as Safe Kids Coalition, Boy or Girl Scout organizations, or local water safety councils. The standards for each station have been at the discretion and control of local organizations. This has resulted in a variety of structure design, maintenance, and oversight in monitoring the structures or the life jackets being made available to the public.

In 2007, the National Operations Center for Water Safety (NOC) conducted a study on the benefits and impacts of establishing a policy requiring visitors to wear life jackets while recreating on our waterways. After careful review of findings, the study team recommended development of a national life jacket loaner program among other options. Since then, Life Jacket Loaner Programs have been heavily encouraged by such national partners as Safe Kids Worldwide, BoatUS, U.S. Coast Guard, Children's Hospital Network, National Safe Boating Council, National Drowning Prevention Coalition, National Association of State Boating Law Administrators, and National Water Safety Congress. (*Appendix A provides a list of potential partners*).

IV. Summary of Guidelines

- A. Auxiliarists are strongly encouraged to implement a life jacket loaner program.
- B. Life jacket loaner programs may be managed at staffed locations or by use of unstaffed loaner boards or kiosk-type stations.
- C. Possible locations for loaner stations include gatehouses, visitor centers, designated swim beaches, marina offices, fuel docks, boat ramps, or similar high visibility facilities.

- D. Loaner station program execution to include routine maintenance and inspections will be at the discretion of the elected leadership per the National SOP.
- E. Signage or printed material must be available to provide the public information on how to properly size and fit a life jacket.
- F. All loaner program printed materials should be printed in language(s) appropriate to project visitation. Display or availability of information offering visual guidance should be used whenever possible.
- G. A waiver of liability will be signed by an adult borrowing a life jacket from an attended life jacket loaner station and will be conspicuously posted at unattended loaner stations. A parent or guardian of a child under the age of 18 will sign the waiver on behalf of the child. If a parent or guardian is not available to sign, the life jacket will still be loaned to the child. Form waivers will be drafted by the DSO-LP who will modify the template at Appendix G as required to conform to law of the state in which the life jacket is to be used. If the DSO-LP determines that state law permits a waiver signed by a minor to be enforceable, a child's waiver will be drafted and provided by the DSO-LP. Waivers for signature and posting should be made available in Spanish in any AOR with a large Spanish speaking population as deemed appropriate by the DCO.

V. Specific Guidance

A. Life Jackets Inspections

1. Schedule – It is important that life jackets be inspected on a routine basis. The managing flotilla will conduct *bi-weekly* inspections of all life jackets currently on display and available for use by visitors at unmanned loaner stations and a *monthly* inspection for staffed loaner stations. Members manning staffed loaner station locations should also be constantly vigilant in checking life jackets as they are returned from visitors or on a rotational basis.
2. Reports – Inspection/Restocking log reports will be completed per the schedule noted above and forwarded to the Flotilla Commander in a timely manner. They should be appropriately maintained for three years for liability purposes. (*See Appendix B for a sample format*).
3. Personnel – Members conducting inspections of life jackets and displays will be designated by the managing flotilla's elected leadership. Members will follow the standards set forth in section V.A.4. to determine the criteria for inspection. It is recommended that all members be properly trained regarding the inspection criteria and other elements of loaner program management.
4. Life jacket inspection criteria checklist - Any life jackets not meeting inspection criteria detailed below must be immediately removed from loaner station/program and destroyed.

- a. Life jackets must be free of rips or tears, and the flotation material must be free of any indication of deterioration. Also check for severe pulling around all seams (especially around straps).
 - b. Straps, belts, and zippers on life jackets must be unaltered, free of dry rot, and in perfect working condition. Metal rings or adjusting buckles must be free of excessive rust and corrosion.
 - c. Verify that all life jackets have a fully legible instruction label and the Coast Guard approval number is listed. If not, the device does not meet carriage requirements for recreational boats.
5. Life jacket inventory- Every effort should be made to have an inventory of extra life jackets on hand to replace damaged or lost jackets. (*A sample letter to borrowers who do not return loaner jackets is in Appendix C*).
 6. Off-season - It is suggested that during winter (or months of traditionally low visitation) that jackets be stored inside to reduce amount of damage from severe weather. Most projects pull all life jackets in from swim beaches during the winter months or if a recreation area, marina, or boat ramp has been closed.

B. Printed Materials/Signage

1. Signs and/or printed materials will be posted on or adjacent to life jacket loaner stations to address fit, size, and physical condition as follows. All text will be printed in languages appropriate for visitor communication.
 - a. Fit – With text or graphics show a properly fitting and buckled life jacket.
 - b. Size – Show visitors how to locate sizing information on the life jacket label or restate the weights associated with each size.
 - c. Physical Condition – Provide visual or written guidance on the importance of checking for damage on life jackets before using them.
2. Printed information on fit and sizing will be provided even if members on hand are fitting jackets for visitors. Visitors must be made aware of their personal responsibility in choosing a properly fitting life jacket in good condition.
3. Signs and other materials should be simple and easily understood – consider using graphics if at all possible.
4. Printed materials and signs should provide directions to visitors as to how the loaner program works. For example: Where do they return life jackets? Are there conditions for the program? (for example: do visitors have to sign a form, work through a member, or just borrow and return the life jackets?).

VI. Recommended Guidance

A. Structure Design & Checks

1. **Single Purpose** – A loaner board or kiosk should be used only for promotion of life jacket wear and associated printed materials. Do not use the kiosk as a general information bulletin board as well.
2. **Readily Accessible** – The loaner board or kiosk should be highly visible and readily accessible, in compliance with the Americans With Disabilities Act.
3. **Safe Structure** – The kiosk or loaner board should be designed and made from materials appropriate to local weather conditions. (*See Appendix E and F for design ideas*). Weather resistant materials are preferable to reduce maintenance and damage to the board. Any type of hook or post used to display life jackets should be blunt and placed at an appropriate height above child's eye level. Do not use sharp or extended attachments, such as nails, to hang the jackets. The structure's design should also meet district and/or project standards for bulletin boards or other kiosk structures.
4. **Structure Checks** - The life jacket loaner board or kiosk should be also checked on a regular basis preferably at the same time the life jackets are being inspected. Members should identify damage or wear from use and follow-up with maintenance requests accordingly. Any damage or wear that could cause injury or poses a threat to a visitor must be fixed immediately or removed from public availability.

B. Life Jackets Used

1. **Quantity** – There is no specific requirement for the quantity of life jackets to be displayed and made available to the visitors. This is something that will need to be determined by the managing flotilla after taking in to consideration the following: activity level at location, type of boating in the area, age of majority of visitors, etc.
2. **Style** – The types or styles of the life jackets should also be determined by the managing flotilla. A variety of Coast Guard approved life jackets are preferred.
3. **Size** – It is recommended that each loaner station have a minimum of at least two life jackets of each size category. (Infant, Child, Youth, Adult)

VII. Procurement of Loaner Program Materials

Several organizations offer grants to aid in setting up a loaner program including BoatUS Foundation, Sea Tow Foundation, U.S. Army Corps of Engineers, local State Parks and Recreation, and State Department of Natural Resources. When soliciting donations, Flotillas should make sure all donations comply with the AUXMAN, Chapter 5.

VIII. Communications Plan and Public Education Initiatives

Projects are encouraged to develop a media campaign and communications strategy to increase awareness about the life jacket loaner program. The communications plan should include a draft news release with photos and interpretive posters explaining the program. Each project is encouraged to tailor draft news releases and posters for their site and should include talking points. All materials will be developed in languages appropriate for project visitation. (*See Appendix D for a sample communications plan, sample press release, and talking points.*) Project promotions may include:

A. Recreation Area Promotion

1. Posters explaining the life jacket loaner program displayed on bulletin boards and/or gate houses.
2. Information posted at boat ramps/marinas that will educate boaters about the loaner program.
3. Where applicable, members will have information/training about this program so they can make visitors aware of how to make use of the life jacket loaner station.

B. Visitor Center Promotion

1. Include information about the life jacket loaner program as part of a water safety education display.
2. Where applicable, inform and train visitor center volunteers and staff about this program so they can familiarize visitors with the program.

C. Marina/Boat Ramp Promotion

1. Provide printed materials to customers/visitors frequenting the location explaining the loaner life jacket program and its benefits.
2. Where applicable, inform and train marina staff about this program so they can be familiar visitors with the program.
3. Make use of organized VSC days at locations to promote the loaner station and educate the visitor.

IX. Examples of Two Types of Loaner Programs

A. Staffed Loaner Stations (e.g. in marinas, near boat ramps, visitor's center/office of site, etc.):

1. Location should display prominent signage promoting the loaner program. Life jackets should be readily available and visible.

2. Loaner stations should be stocked with U.S. Coast Guard approved life jackets in various sizes in limited quantities.
3. Members may ask visitors if they would like to borrow a free loaner life jacket for the day.
4. Borrower will be reminded to return the life jacket upon departure from location. The use of a sign-out form is not mandatory but may be used.
5. Life jackets must be inspected on a routine basis for wear, and unsafe life jackets must be removed. Inspection reports should be kept on file for three years for liability purposes.
6. Interpretive posters, signs, or other types of notices may be posted at launch ramps, visitor centers, restrooms, swim beaches, etc., to increase visitors awareness about the program and encourage boating and water safety. Bilingual signage may be provided at the manager's discretion.

B. Unstaffed Loaner Stations:

1. Loaner stations at swim beaches, boat ramps, marinas, or similar facilities should have signs, posters, or other types of notices explaining the loaner program.
2. U.S. Coast Guard approved life jackets should be available in various sizes.
3. Loaner station signs should instruct visitors who borrow life jackets on an honor system to return the jacket to the station before leaving the park.
4. Life jackets must be inspected on a routine basis for wear, and unsafe life jackets must be removed. Inspection reports should be kept on file for 3 years for liability purposes.
5. Posters, signs, or other types of notices may be posted at launch ramps, visitor centers, restrooms, swim beaches, etc., to increase visitors' awareness about the program and encourage boating and water safety. Bilingual signage may be provided at the manager's discretion.

Appendix A

Potential Partnership Opportunities

PFD Donations/Discounts/Grants:

Cooperating Organizations
Boat U.S. Foundation
National Safe Boating Council
Safe Kids Coalition
National Marine Manufacturers Association
Sea Tow Foundation

Local Water Safety Councils

Retail store locations

Wal-Mart
Target

Life Jacket Manufacturers

Stearns
Mustang
Revere

Local Sporting Goods/Outdoor/Boating Stores

Dicks Sporting Goods
Sports Authority
Kmart
West Marine
Cabelas
Gander Mountain
Bass Pro Shops

Military/Civic Organizations

VFW
American Legion
Kiwanis
Shriners
YMCA/YWCA
American Red Cross
Rotary
Lions Club

Loaner Station Materials:

Home Depot
Lowe's Home Improvement Warehouse
Ace Hardware
True Value Hardware
Local hardware stores
Wal-Mart
Target

Other Partners:

U.S. Coast Guard
U.S. Army Corps of Engineers
U.S. Power Squadrons
National Water Safety Congress
"Kids Don't Float" Campaign – Alaska
Safe Kids USA

Note: Solicitation of donations by Auxiliary units in support of this program must follow all procedures specified by COMDTINST M16790.1(series) Section 5.H.1.c.

CODES AND COMMENTS:

U = Unserviceable R = Removed from Inventory

Life Jacket #	Code and Comment	Corrective Action	Date Removed from Service

RESTOCKING LOG

# Adult Replaced	# Youth Replaced	# Child Replaced	# Infant Replaced	Jackets Missing	Jackets Damaged

Reviewed by: _____

Title/Office: _____

Appendix C

Sample Letter to Borrowers for Unreturned Life Jackets (Optional for Staffed/Manned Locations)

The following is a sample letter to send to remind borrowers to return life jackets. It is at the discretion of the Flotilla Commander to determine the level of enforcement to be used for this program.

Dear Mr. Smith:

Thank you for making use of our loaner life jacket station at *Lake Mead* and taking a major step towards being safer on the water.

Our records show that you borrowed *two* life jacket(s) on *April 3, 2013*, and mistakenly forgot to return *them*. We would ask that you please return the jacket(s) to the *North Boat Ramp location* as soon as possible. The life jacket loaner program depends on life jackets being returned for others to use, and we appreciate your cooperation in this matter.

Please contact, John A. Doe (417-555-1212) if you have any questions regarding this matter.

Sincerely,
Thomas B. Auxiliarist
Flotilla Commander, Flotilla _____

Appendix D

Life Jacket Loaner Program Sample Communication Plan

1. Purpose

This document provides a communication strategy template in cooperation with Public Affairs to use in launching a new life jacket loaner program campaign or to increase awareness enhance an existing program.

2. Responsibilities

- A. All personnel should reference this plan when fielding questions/concerns from members of the public, partners, and/or stakeholders.
- B. Work with Public Affairs (PA) to distribute news releases/and or media advisories to increase awareness.
- C. Conduct direct outreach with visitors and partners/stakeholders to explain the program.

3. Background

The life jacket loaner program provides the public with free use of life jackets on a first-come, first-served basis. Research shows that most drowning could have been prevented if a life jacket had been worn by the victim. The goals for this program are to increase life jacket wear during water-based activities as well as to educate the visiting public on the importance of proper use and fit.

Life jacket loaner stations have been successfully used since the mid-1980s by various organizations as a tool in reducing public recreation-related fatalities on their waters. Most of these stations offer various sizes of life jackets from infant to adult in limited quantities. Demand for use of the life jackets has generally exceeded the available supply. Many of the loaner stations in existence have cooperatively been installed and maintained by local partners, such as Safe Kids Coalition, Boy or Girl Scout organizations, or local water safety councils. The standards for each station have been at the discretion and control of the local lake manager. This resulted in a variety of structure design, maintenance, and oversight in monitoring the structures or the life jackets being made available to the public.

In 2007, the National Operations Center for Water Safety (NOC) conducted a study on the benefits and impacts of establishing a policy requiring visitors to wear life jackets while recreating on our waterways. After careful review of findings, the study team recommended development of a national life jacket loaner program among other options. Since then, Life Jacket Loaner Programs have been heavily encouraged by such national partners as Safe Kids Worldwide, BoatUS, US Coast Guard, Children's Hospital Network, National Safe Boating Council, National Drowning Prevention Coalition, National Association of State Boating Law Administrators and National Water Safety Congress. (*Appendix A provides a list of potential partners*).

4. Potential Audiences

A. Internal

1. Auxiliary membership
2. Sister/neighboring projects
3. Operations
4. Flotilla/Division/District

B. External

1. Nearby vendors/concessionaires
2. Local residents who regularly visit the recreation areas
3. Local law enforcement agencies that patrol/respond to the recreation areas
4. Marina tenants
5. Local media
6. Local civic groups/clubs (Rotary, Lions, American Legion, Fishing Clubs, etc.) that have a vested interest in the facility
7. Community leaders (city/town council reps, county reps, congressional district reps, teachers)

5. Goal, Strategy, Tactics

A. **Goal:** Ensure awareness of life jacket loaner program and increase awareness of Auxiliary's commitment to visitor/water safety.

B. **Strategies:** Communicate program intent and policy proactively through internal briefings, media releases, social media outreach, and direct visitor interaction.

C. Suggested Tactics

1. News release announcing program
2. Water safety event at location to introduce program
3. Facebook, Twitter announcements about program
4. Distribute fact sheet to local businesses, partner agencies
5. Pitch appearances on local radio/TV stations to discuss program
6. Direct outreach to partners/stakeholders

6. Key Messages and Talking Points

A. Life jackets save lives.

- Since 1998, 90 percent of drowning victims were not wearing life jackets.
- When accidents happen, life jackets buy time for successful rescues.

B. Accidents happen. They don't have to be fatal.

- Many people who drown never expected to end up in the water. Even experienced swimmers can quickly get into trouble.
- Safe boating is not just the responsibility of the person behind the wheel; it applies to everyone on board.
- Most boaters do not plan on falling overboard, and when they do, it is too late. Putting on a life jacket when you need it is like trying to put on a seat belt just before a crash.
- Adults can drown in less than a minute; children in as few as twenty seconds.

C. Safety of the boating public is our top concern.

- Life jackets are essential to safe water recreation, and we want everyone who visits our park to be able to do so safely.
- Providing loaner life jackets boaters have the chance to enjoy our waters safely.

D. Following some simple rules can help you stay alive.

- Always wear a life jacket (*Siempre use un chaleco salvavidas.*)
 - Children should wear life jackets when playing in or near the water. (*Niños deben usar chalecos salvavidas al jugar adentro o cerca del agua.*)
 - Everyone should wear life jackets from the time they arrive at the boat ramps until they tow boat out of the water. (*Cada uno debe usar chalecos salvavidas a partir del tiempo momento que llegan a las rampas de botes hasta que remolquen el bote fuera del agua.*)
 - If you don't have a life jacket, use a loaner. (*Si usted no tiene un chaleco salvavidas, hable con un guarda parques o un asistente del parque sobre nuestro programa al prestamista.*)
- Always swim with a buddy. (*Nada siempre con un amigo.*)
- Learn how to swim well. (*Aprende a nadar bien.*)
- Never dive into unknown waters. (*Nunca se zambulla en las aguas desconocidas.*)
- Parents, always watch your children! (*¡Padres, vigilen siempre a sus niños!*)
- Always swim in designated areas. (*Siempre nade en áreas designadas.*)
- Take a Boating Safety Course. (*Tome un curso sobre la seguridad del paseo en bote.*)
- Always be weather wise; watch for summer storms. (*Conozca el estado del tiempo; vigile por las tormentas del verano.*)

Sample Press Release

For Immediate Release:
(insert date)

Life Jacket Loaner Program at (insert project name)

(Insert Project Name, State Abbreviation) – (insert project name), managed by the U.S. Coast Guard Auxiliary (insert flotilla name), will offer a limited number of life jackets for loan to boaters beginning (insert Month, Date, Year).

“Quote from flotilla commander describing why the site was chosen to implement the program and how it’s expected to improve safety,” said Flotilla Commander – insert name)

“Statistically, we know that 90 percent of drowning victims were not wearing life jackets. In many of these incidents, we know that life jackets, if properly worn, would have increased their chances of survival,” said (Flotilla Commander – insert name).

(Describe particulars of local program)

The life jacket loaner program is a supplement program for those who forgot their life jacket. Boaters should not rely on this program as a sole source for their life jackets. If a life jacket is borrowed from the loaner program, it should be returned the same day it is borrowed.

Visitors with questions about the program are encouraged to contact the (insert name) at (insert contact information).

Appendix E

Examples of Kiosk / Shelter / Loaner Board Designs



Loaner Kiosk Type



Loaner Kiosk Type



Loaner Shelter Type



Loaner Board Type

Appendix F

Sample Life Jacket Loaner Station Design Plans

KIDS DON'T FLOAT!

PFD Otter says:

- The best lifejacket is the one you WEAR.
- Always wear a lifejacket when in a boat, on a dock or near water.
- Make sure your lifejacket fits properly and the buckles are fastened.
- Never swim alone - adult supervision is a must!

How to properly fit a lifejacket

Fit to Size Fasten All Straps Lift to Test

Call this number for more information about "Kids Don't Float!"
Please let us know if one of our life jackets saved your life!

Program Operator: U.S. Coast Guard, Alaska Office of Boating Safety, Sitka, Alaska

Program Sponsor: U.S. Coast Guard, Alaska Office of Boating Safety, Sitka, Alaska

LIFEJACKET LOANER STATION

Lifejacket Loaner Program Loaner Station Construction Diagrams

Kids Don't Float Sign Kit

Kit Contents:

- 1) Kids Don't Float sign (packaged separately)
- 1) 1lb. Box - 2" coated screws (exterior grade)
- 1) 1lb. Box - 3" coated screws (exterior grade)
- 1) package 4 - lag bolts with washers 3/8" x 2" (use with free standing mount option)
- 1) package 2 - lag bolts with washers 3/8" x 3" (use with free standing mount option)
- 6) cast zinc coated hooks with mounting screws
- 2) exterior hinges with mounting screws (use to mount sign on storage box option)
- 1) package 4 - bolts with washers and nuts 3/8" x 2" (use to mount sign on storage box option)
- 1) exterior hasp with mounting screws and washers (use with storage box option)
- 1) Loaner Station Construction Diagrams*

* Depending on the application, you may need to modify the design to suit your specific needs

WARNING

PRIOR TO STARTING YOUR PROJECT

- **Check on local building construction code & permit requirements including those for signage.**
- **Check with the appropriate local utility companies (e.g. gas, electric) concerning underground lines prior to digging *any* holes for footings. Failure to do so may result in serious injury or death.**
- **To ensure safety and lasting structural stability with your sign project, use only EXTERIOR grade screws and other hardware.**

Wall Mount Sign

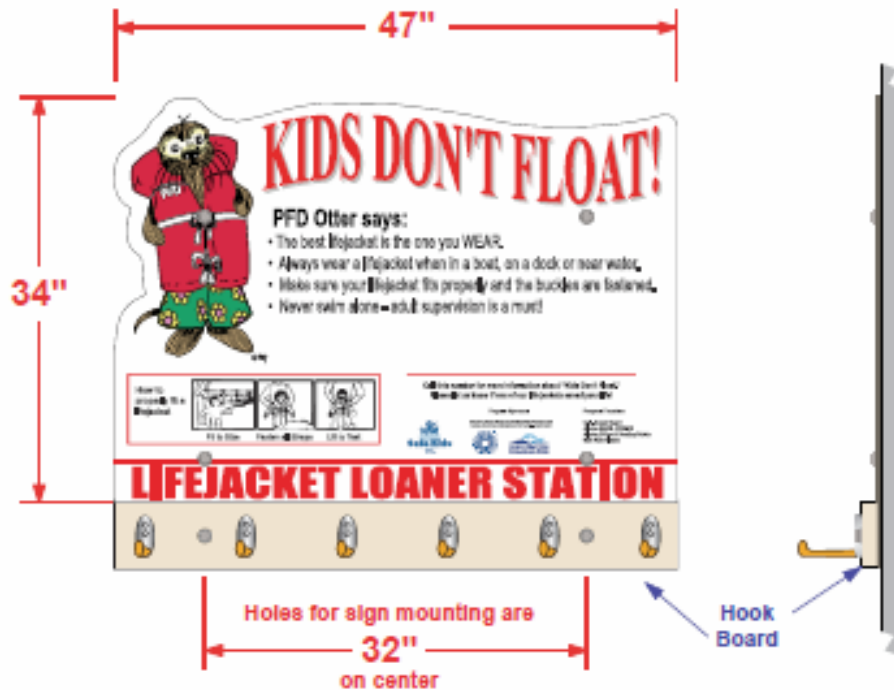

Wall Mount Sign - Materials

- 1) Kids Don't Float sign (included in kit)
- 1) package 4 - lag bolts with washers 3/8" x 2" (included in kit)
- 1) package 2 - lag bolts with washers 3/8" x 3" (included in kit)
- 6) cast zinc coated hooks with mounting screws (included in kit)
- 1) 2" x 6" x 47" pressure treated Hook Board

Mounting - "Kids Don't Float" (KDF) Sign:

- ensure bolt holes will align with a solid material (wall stud, fence rails, etc)
- if this is not possible, you may attach a sheet of exterior grade plywood (cut to size) to your surface and then mount the KDF sign to it
- attach the sign using the included lag bolts and washers - 2" bolts for the sign, 3" bolts for the 2" x 6" x 47" "hook board"
- attach the included hooks to your 2" x 6" x 47" pressure treated board
- mount the assembled "hook board" under the kdf sign using the included lag screws

Free Standing Sign

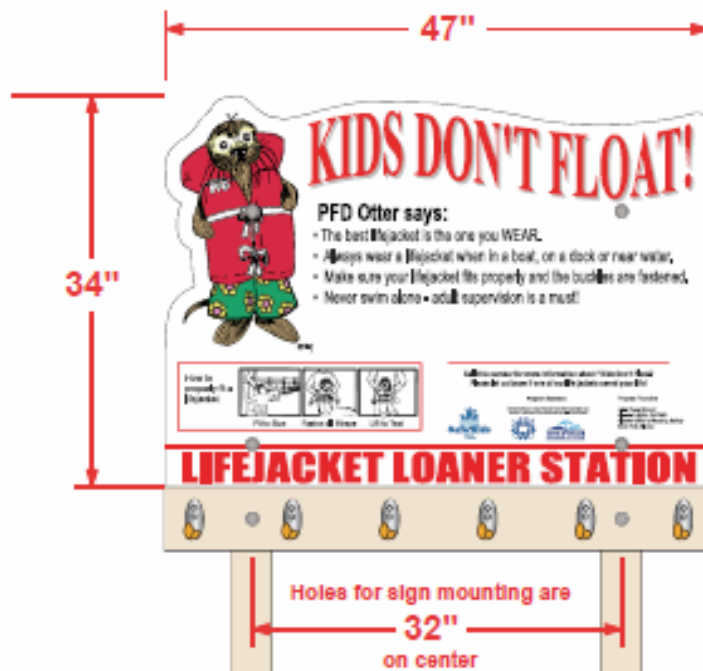

Free Standing Mount - Materials in Kit:

- 1) Kids Don't Float Sign (Included in Kit)
- 1) package 4 - lag bolts with washers 3/8" x 2" (Included in kit)
- 1) package 2 - lag bolts with washers 3/8" x 3" (Included in kit)
- 6) cast zinc coated hooks with mounting screws (Included in kit)

Additional Materials Needed (Pressure Treated Lumber):

- 1) 2" x 6" x 47" Hook Board
- 2) 4" x 4" posts (height will vary depending on depth of footing)
- 4) bags concrete mix

Installing & mounting - "Kids Don't Float" (kdf) sign:

Prior to digging post holes, utility companies should be contacted to mark lines.
Install post and footings following local codes and ordinances.

To mount KDF sign, follow directions on page 2

Free Standing Sign with Roof



Free Standing Mount w/ Roof - Materials in Kit:

- 4) Lag Bolts with Washers 3/8" x 2"
- 2) Lag Bolts with Washers 3/8" x 3"
- 6) Zinc Coated Hooks with mounting screws
- 1) 1lb. Box - 2" Coated Screws
- 1) 1lb. Box - 3" Coated Screws

Additional Materials Needed (Pressure Treated Lumber):

- 1) 2" x 6" x 47" - Hook Board
 - 2) 2" x 4" x 2' 5" - Bottom Braces - 45° cut - both ends
 - 2) 2" x 4" x 1' 10" - Back Braces - 45° cut - one end
 - 2) 2" x 4" x 1' 11 1/2" - Front Braces - 45° cut - one end
 - 1) 2" x 4" x 3' 6 1/2" - Top Beam
 - 2) 2" x 4" x 3' 6 1/2" - Cross Beams - Notch cut 45° angle on bottom corner of both ends (see diagram)
 - 1) 4' x 2" x 1/2" Plywood - Front Roof Panel
 - 1) 4' x 1' 11 1/2" x 1/2" Plywood - Back Roof Panel
 - 2) 2' 5" x 1' 11 1/2" x 1/2" Plywood - Side Panels (triangles)
 - 2) 4" x 4" Post (Height will vary depending on depth of footing)
 - 4) Bags of Concrete Mix
- Exterior paint or standard asphalt shingles & roofing nails

To mount KFD sign - follow directions on page 2

Roof Assembly

Cut framing & panels assemble as shown using coated screws included in kit.

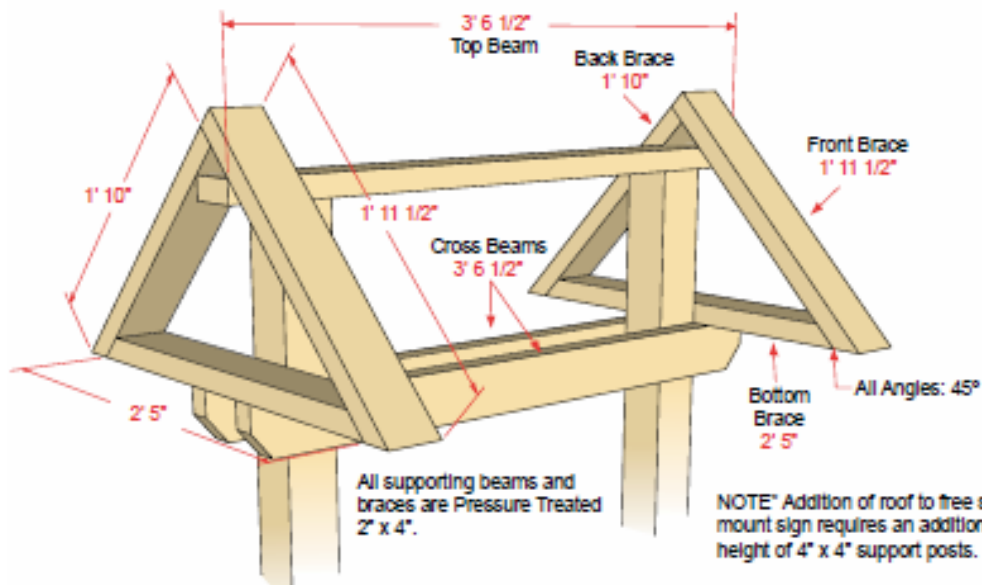

Lifejacket Storage Box - Materials

Materials included in KDF Kit:

- 1) Kids Don't Float Sign (Packaged Separately)
- 6) Zinc Coated Hooks with Mounting Screws (Included In Kit)
- 1) 1lb. Box - 2" Coated Screws (Include In Kit)
- 1) 1lb. Box - 3 1/2" Coated Screws (Included In Kit)
- 2) Exterior Hinges with Mounting Screws (Included In Kit)
- 1) Package 4 - Bolts with Washers and nuts 3/8" x 2" (Included In Kit)
- 1) Exterior Hasp with Mounting Screws and Washers (Included In Kit)

The following materials should all be pressure treated lumber:

- 1) 2" x 6" x 4' 1/2" - Hook Board
- 5) 2" x 4" x 4' 1/2" - Cross Braces
- 2) 2" x 4" x 4' 2 7/8" - Top end cut at 30 degree angle (up to 4' 4 7/8") - Back Post
- 2) 2" x 4" x 3' 7" -Top end cut at 30 degree angle (up to 3' 9") - Front Post
- 2) 2" x 4" x 10 1/4" - Bottom Side Braces
- 2) 2" x 4" x 11 7/8" - Both ends cut at 30 degree angle – Top Side Braces
- 2) 2" x 4" x 4' 1/2" - Door Cross Braces
- 2) 2" x 4" x 4' 1/2" - Door Vertical Braces

All exterior materials should be 3/4" thickness and be either pressure treated or sealed and painted prior to assembly.

From three 4' x 8' sheets of 3/4" plywood, cut the following panels:

- 1) 4' 8 1/2" x 2' - ROOF PANEL
- 2) 3' 7 3/4" x 1' 6" - SIDE PANELS - top end cut at 30° angle (up to 4' 6 1/8")
- 2) 4' 5" x 3 1/2" - HORIZONTAL FACE BOARDS
- 2) 2' 10 3/8" x 2 3/8" - VERTICAL FACE BOARDS
- 1) 4' x 4' 3 1/2" - BACK PANEL (see Rear View)
- 1) 4' 3 1/2" x 1' 4 1/2" - FLOOR PANEL (To ensure adequate air circulation within the storage box, holes should be drilled in this panel as needed for water drainage and ventilation).
- 1) Screen material (e.g. 1" x 1" wire mesh) for air space above Front & Back Panel (see Rear View)

Lifejacket Storage Box - Frame Design

NOTE*** REAR CROSS BRACE Should be attached 4" below top of BACK POST to allow for air circulation.

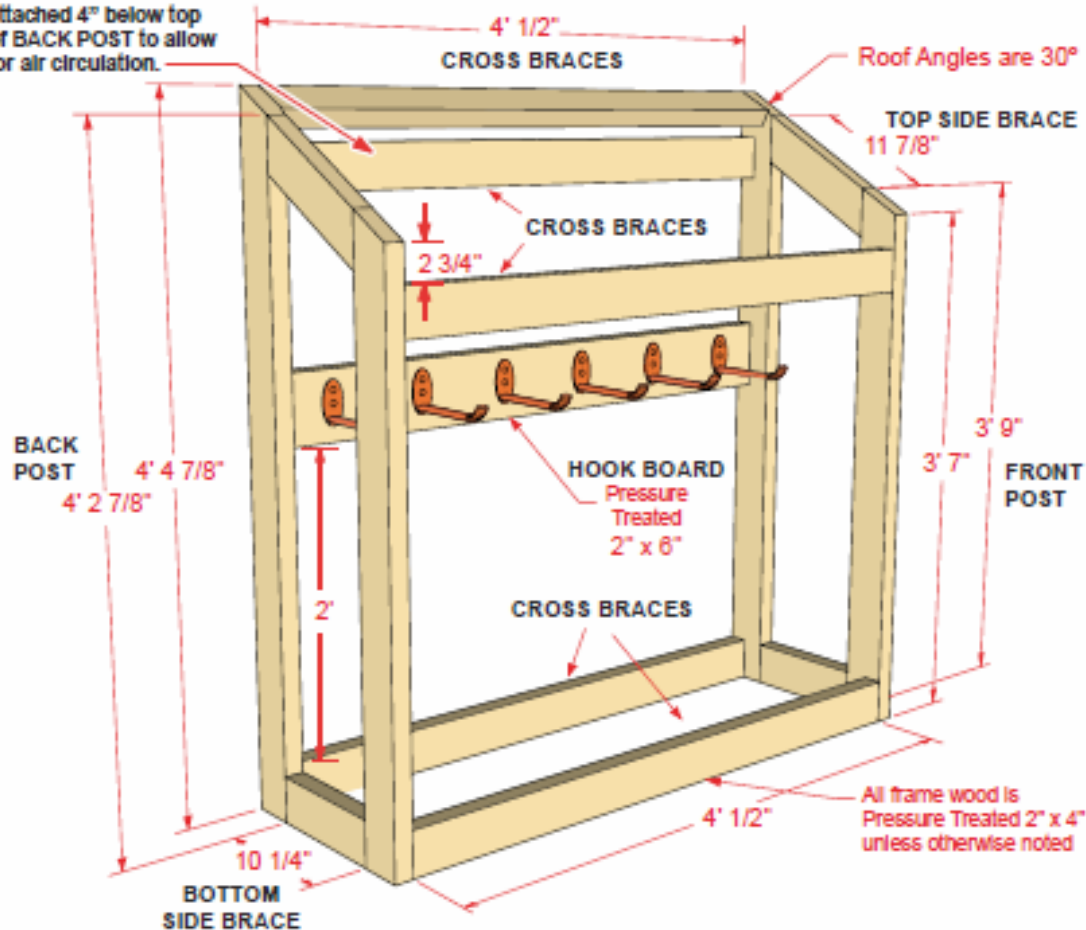

Lifejacket Storage Box (Frame) Materials Included in Kit:

6) Zinc Coated Hooks with Mounting Screws (Included In Kit)

1) 1lb. Box - 2" Coated Screws (Include In Kit)

1) 1lb. Box - 3 1/2" Coated Screws (Included In Kit)

Additional Materials Needed (Pressure Treated Lumber):

1) 2" x 6" x 4' 1/2" - Hook Board

5) 2" x 4" x 4' 1/2" - Cross Braces

2) 2" x 4" x 4' 2 7/8" - Back Post - Top end cut at 30 degree angle (up to 4' 4 7/8")

2) 2" x 4" x 3' 7" - Front Post - Top end cut at 30 degree angle (up to 3' 9")

2) 2" x 4" x 10 1/4" - Bottom Side Braces

2) 2" x 4" x 11 7/8" - Top Side Braces - Both ends cut at 30 degree angle

Cut Framing & assemble as shown using coated screws Included In kit. Hooks should be mounted on 2" x 6" x 4' 1/2" Hook Board spaced approximately 8" apart on center.

Lifejacket Storage Box - Exterior Design

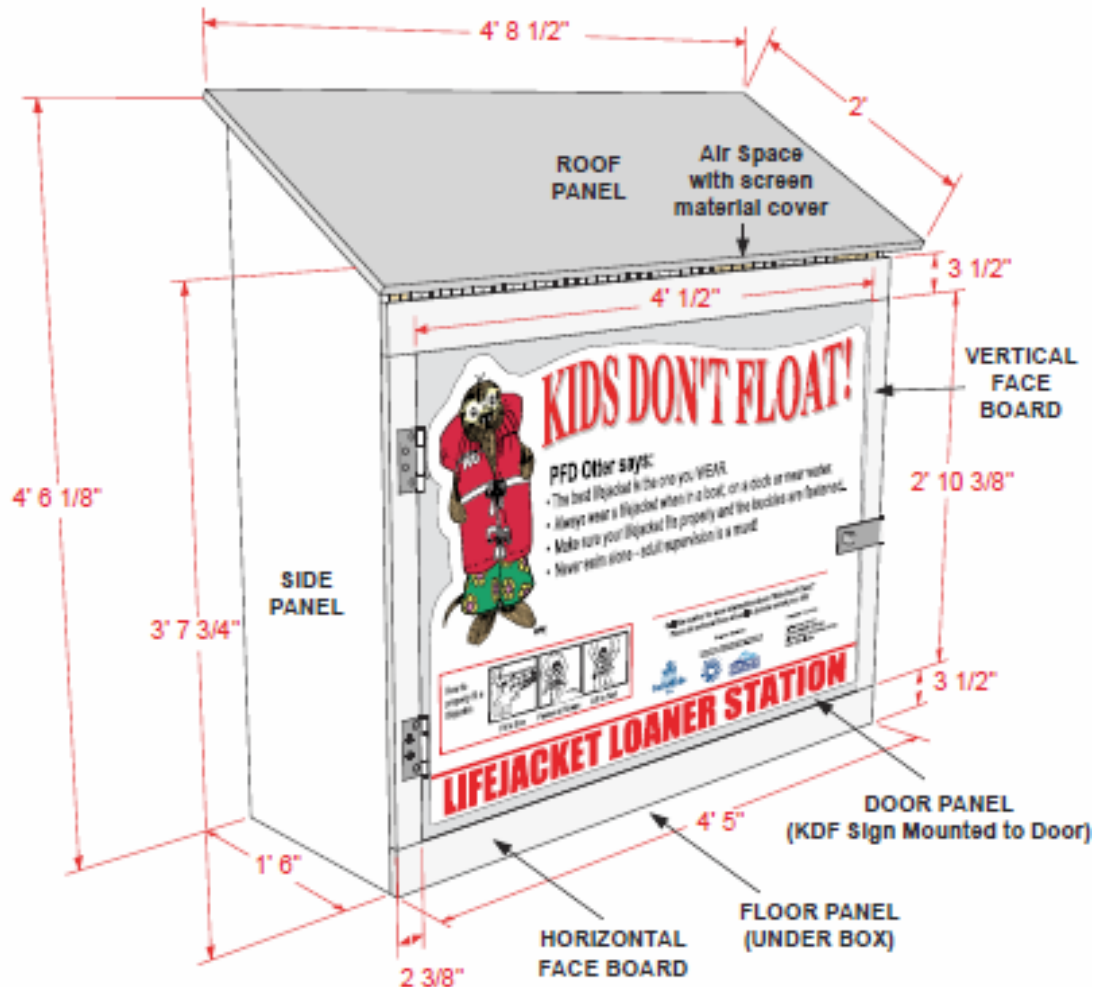

Lifejacket Storage Box (Exterior) Materials:

All exterior materials should be 3/4" thickness and be either pressure treated or sealed and painted prior to assembly.

- 1) 4' 8 1/2" x 2' - ROOF PANEL
- 2) 3' 7 3/4" x 1' 6" - SIDE PANELS - top end cut at 30° angle (up to 4' 6 1/8")
- 2) 4' 5" x 3 1/2" - HORIZONTAL FACE BOARDS
- 2) 2' 10 3/8" x 2 3/8" - VERTICAL FACE BOARDS
- 1) 4' x 4' 3 1/2" - BACK PANEL (see Rear View)
- 1) 4' 3 1/2" x 1' 4 1/2" - FLOOR PANEL (To ensure adequate air circulation within the storage box, holes should be drilled in this panel as needed for water drainage and ventilation).
- 1) Screen material (e.g. 1" x 1" wire mesh) for air space above Front & Back Panel (see Rear View)

Cut exterior panels & attach to frame as shown using coated screws included in kit.

Prior to installing the roof panel, a screen material (e.g. 1" x 1" wire mesh) should be installed over the front & rear airspaces.

Lifejacket Storage Box - Exterior Design Rear View

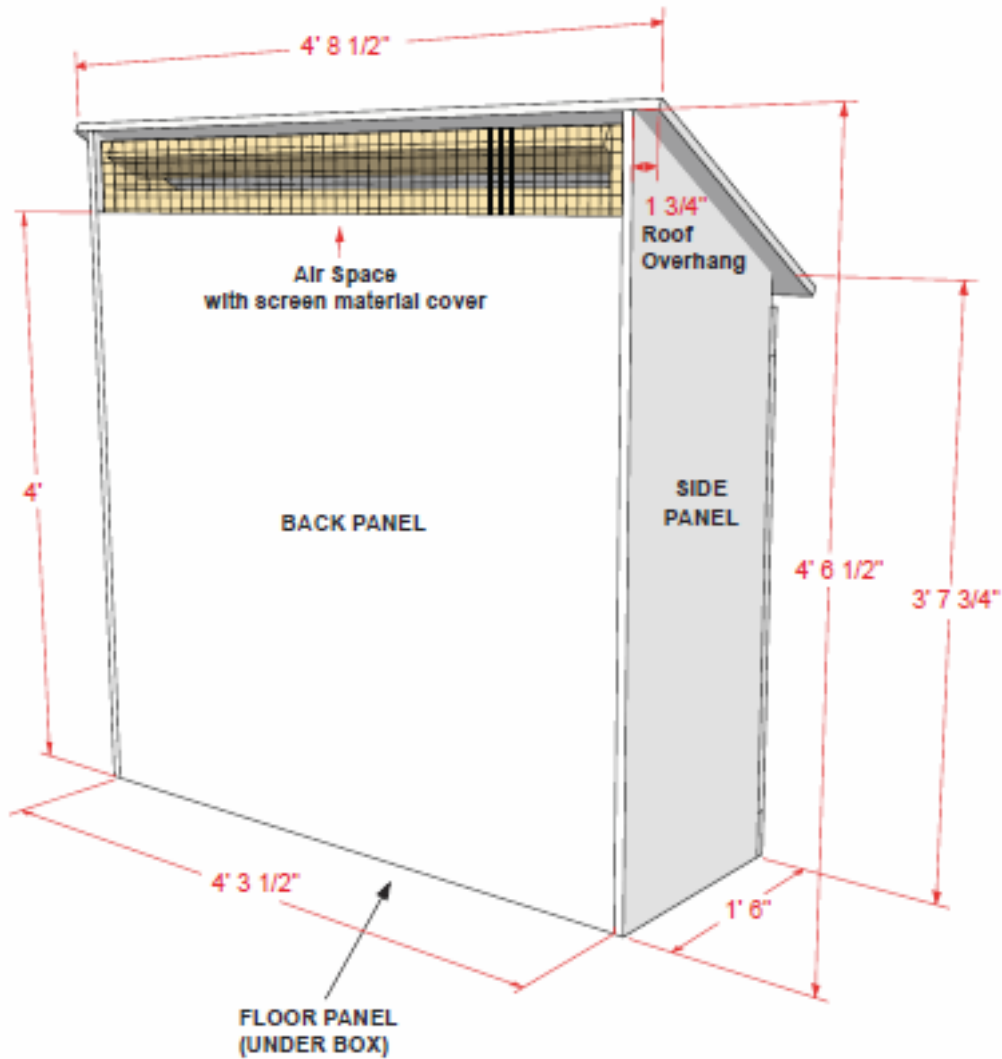

To ensure adequate air circulation within the storage box, holes should be drilled in the Floor Panel as needed for water drainage and ventilation.

Lifejacket Storage Box Door & Sign Installation

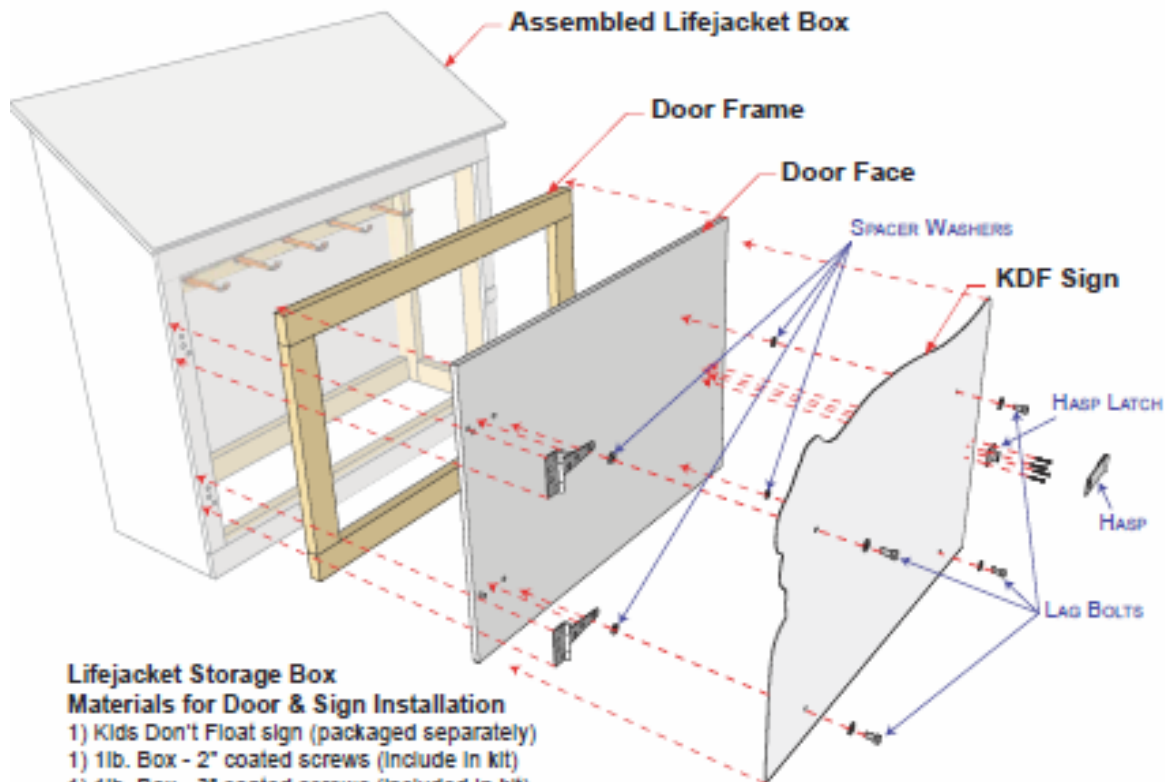

Lifejacket Storage Box

Materials for Door & Sign Installation

- 1) Kids Don't Float sign (packaged separately)
- 1) 1lb. Box - 2" coated screws (include in kit)
- 1) 1lb. Box - 3" coated screws (include in kit)
- 2) exterior hinges with mounting screws (include in kit)
- 1) package 4 - bolts with washers and nuts 3/8" x 2" (include in kit)
- 1) exterior hasp with mounting screws and washers (include in kit)

All exterior materials should be 3/4" thickness and be either pressure treated or sealed and painted prior to assembly.

- 1) assembled lifejacket storage box
- 2) 2" x 4" x 4' Door Frame Cross Braces
- 2) 2" x 4" x 1' 2 3/4" Door Frame Vertical Braces
- 1) 2' 10 3/8" x 4' x 3/4" - Door Face Panel

Cut Door Frame Braces & Door Face Panel & assemble as shown using coated screws included in kit. Mount hinges to vertical face boards approximately 6" from top & bottom horizontal boards. Mount kdf sign to door face panel using included bolts with included washers mounted between kdf sign & door face panel. Drill 4 holes & mount hasp latch to face of kdf board ensuring that there is a supporting washers between the sign & door face panel. Mount the hasp to the right vertical face board (this may require washers as well).

APPENDIX G

Waiver and Release from Liability to be Signed by Adults

In consideration of my borrowing one or more life jackets from the U.S. Coast Guard Auxiliary at no cost, I certify that I have inspected all such life jackets for appropriate fit and function. I agree on behalf of myself, the children in my care, my heirs and assigns, to indemnify and hold harmless the U.S. Coast Guard Auxiliary (the loaner) and the U.S. Coast Guard, and do hereby release them from any and all claims of liability for loss, personal injury, death or damages of any kind associated with, or arising from, the use of said life jackets. The U.S. Coast Guard Auxiliary offers this program as a free public service using U.S. Coast Guard approved equipment. As the U.S. Coast Guard and U.S. Coast Guard Auxiliary have no control over their actual usage, I understand and agree that they assume no liability for the use or misuse of the life jackets.

I understand that personal information recorded on this form will only be used for the purpose of ensuring the proper return of the life jackets and that my personal information will not be shared with other parties.

_____ **Dated:** _____

_____ **Dated:** _____

Witness

Posted Waiver and Release from Liability at Unattended Kiosks

In consideration of my borrowing one or more life jackets from the U.S. Coast Guard Auxiliary at no cost, I certify that I have inspected all such life jackets for appropriate fit and function. I agree on behalf of myself, the children in my care, my heirs and assigns, to indemnify and hold harmless the U.S. Coast Guard Auxiliary (the loaner) and the U.S. Coast Guard, and do hereby release them from any and all claims of liability for loss, personal injury, death or damages of any kind associated with, or arising from, the use of said life jackets. The U.S. Coast Guard Auxiliary offers this program as a free public service using U.S. Coast Guard approved equipment. As the U.S. Coast Guard and U.S. Coast Guard Auxiliary have no control over their actual usage, I understand and agree that they assume no liability for the use or misuse of the life jackets.

By taking a life jacket from this location, I agree to be bound by the terms of this release.