

**THIS CARD IS MAINTAINED TO PROVIDE PROCEDURAL  
TEXT ONLY AND IS NOT REPORTED TO ACMS**

**CEINUM RA-KB00-010**

**1 MD 3183V22 INFLATABLE PFD INSP/ACCPT**

REFERENCES:

MPC [KB0096.0](#)

MPC [KB0107.0](#)

TOOLS/TEST EQUIPMENT:

NONE

EXPENDABLES:

NONE

CONSUMABLES:

Accessory Pocket, (selected):

Black, P/N: MA6000-BK, CAGE: 1LV23, NIIN: N/A (2) (Deployable Specialized Forces (DSF) only)

Orange, P/N: MA6000-OR, CAGE: 1LV23, NIIN: N/A (2)

Cord, Fibrous (Type 1 Nylon), P/N: MIL-C-5040, CAGE: 81349, NIIN: 002402154

Marker, Tube Type (Permanent), P/N: 7520-00-973-1059, CAGE: 83421, NIIN: 009731059 (Or equivalent)

**A INSPECT PFD**

1. Apply locally generated serial number to the yellow portion of the right inflation cell using permanent marker, P/N: 7520-00-973-1059, (Refer to [Figure 1](#)).

*NOTE: Black (BK) pouches are authorized for DSF personnel only.*

2. Attach an accessory pocket, P/N: MA6000-BK, or, P/N: MA6000-OR, to each side of the PFD waist strap, (Refer to [Figure 1](#)).
3. Inspect PFD, (Refer to Steps [2 A 1.](#) through [2 A 11.](#)).
4. Leak test PFD, (Refer to Steps [2 B 1.](#) through [2 B 9.b.](#)).

**B ATTACH SURVIVAL EQUIPMENT AND PYROTECHNICS**

*NOTE: Non-boat crew passengers (i.e. Boarding Officers, Boarding Team members, Inspection staff) who have completed the Mustang Survival MD-3183v22 performance qualification standard may wear the MD-3183 with a Personal Marker Light (PML) or strobe light and whistle attached.*

1. Inspect the following survival equipment and pyrotechnics, (Refer to MPC [KB0107.0](#) and MPC [KB0096.0](#)):
  - a. Signal whistle.

Distribution Statement D: Distribution authorized to the DHS/CG/DoD and their contractors Administrative/Operational use, 10/24/16. Other requests shall be referred to the appropriate asset product line.

WARNING: This document contains technical data whose export is restricted by the Arms Export-Control Act (Title 22, U.S.C., Sec 2751, et. seq.) or the Export Administration Act of 1979, as amended, Title 50, U.S.C. App 2401 et. seq. Violations of these export laws are subject to severe criminal penalties. Disseminate in accordance with provisions of DoD Directive 5230.25.

DESTRUCTION NOTICE: For classified documents, follow the procedures in DoD 5200.22-M, National Industrial Security Program Operating Manual, Section 5-705 or DoD 5200.1-R, Information Security Program Regulation, Chapter VI, Section 7. For unclassified, limited documents, destroy by any method that will prevent disclosure of contents or reconstruction of the document.



- b. Strobe light.
  - c. Personal Locator Beacon (PLB).
  - d. Signal mirror.
  - e. MK-79 personal distress kit.
  - f. MK-124 smoke and illumination signal.
  - g. Survival knife.
2. Attach the following equipment to the webbing loop inside the corresponding accessory pocket using a sear cut, 42 inch length of Type I nylon cord, P/N: MIL-C-5040, secured with a bowline and an overhand knot on each end, (Refer to [Figure 1](#), [Figure 2](#), and [Figure 3](#)):

*NOTE: Finished length of line from knot to knot for each item below shall be 36 inches or greater.*

- a. Signal whistle, (left accessory pocket).  
*NOTE: Sirius LED strobe lights are furnished with a manufacturer installed 42 inch lanyard. The manufacturer installed lanyard is acceptable for use until no longer serviceable.*
  - b. Strobe light, (left accessory pocket).
    - (1) Replace lanyard using a sear cut, 42 inch length of Type I nylon cord secured with a bowline and overhand knot on each end, (If required).
  - c. PLB, (right accessory pocket).
  - d. MK-79 personal distress kit, (left accessory pocket).
  - e. Signal mirror, (left accessory pocket).
3. Attach survival knife sheath to the webbing strap located in the left accessory pocket survival knife pouch.  
*NOTE: Finished length of line from knot to knot for each item below shall be 36 inches or greater.*
4. Attach survival knife to the webbing strap located in the survival knife pocket using a sear cut, 42 inch length of Type I nylon cord secured with a bowline and an overhand knot on each end.
- a. Place survival knife into sheath.
5. Attach one MK-124 smoke and illumination signal to the PFD.
- a. Attach a retention harness to the MK-124 using a sear cut, 72 inch length of Type I Nylon cord with two surgeon's knots, (Refer to [Figure 4](#), [Figure 5](#), and [Figure 6](#)).  
*NOTE: Finished length of line from knot to knot for each item below shall be 36 inches or greater.*
  - b. Attach the opposite end of the retention harness to the webbing loop inside the left accessory pocket using a bowline with an overhand knot.
6. Document any discrepancies in the MD 3183v22 Maintenance Log.



**2 SEMI-ANNUAL MD 3183V22 INFLATABLE PFD INSP/LEAK TEST**

REFERENCES:

MPC [KB0096.0](#)  
MPC [KB0107.0](#)

TOOLS/TEST EQUIPMENT:

NONE

EXPENDABLES:

NONE

CONSUMABLES:

Accessory Pocket (selected) (If required):

Black, P/N: MA6000-BK, CAGE: 1LV23, NIIN: N/A (Deployable Specialized Forces (DSF) only)

Orange, P/N: MA6000-OR, CAGE: 1LV23, NIIN: N/A

Leak Test Compound, P/N: MIL-PRF-25567E, CAGE: 81349, NIIN: 006211820 (Or equivalent)

Life Preserver, Vest, P/N: MD3183-22, CAGE: 1LV23, NIIN: N/A (If required)

Repair Kit, HIT Window, P/N: RE0013, CAGE: 1LV23, NIIN: N/A (If required)

**A INSPECT PFD**

**WARNING**

**VARIOUS STEPS IN THIS PROCEDURE EMPLOY ITEMS ON THE HAZARDOUS MATERIALS LIST. BEFORE EXECUTING THIS MPC, REFER TO THE APPLICABLE MSDS/SDS FOR FULL SAFETY AND HANDLING PROCEDURES.**

1. Check PFD over its entire surface for the following:
  - a. Cuts.
  - b. Tears.
  - c. Seam separation.
  - d. Loose stitching.
2. Remove PFD from service if any of the above discrepancies are noted.

*NOTE: Repairs are authorized only to the limits of the unit's capabilities. Repairs are to be made using nylon upholstery thread the same color as the mesh and must not detract from the neat appearance and proper function of the gear. Unit level repairs to the inflatable bladders are not authorized.*

- a. Repair PFD, if within unit capabilities.
- b. Send PFD to repair facility, if repair cost does not exceed the replacement cost.
- c. Replace PFD, P/N: MD3183-22, if repair cost exceeds the replace cost.



*NOTE: A damaged or missing Hydrostatic Inflator Technology (HIT) window, (Refer to [Figure 1](#)), does not affect the performance of the PFD's hydrostatic inflator. The PFD need not be removed from service solely for damaged or missing HIT window. The HIT window may, but is not required to be, replaced at the discretion of the unit. Replacement kits are available through Mustang Survival.*

3. Inspect PFD for damaged HIT window.
  - a. Replace HIT window, P/N: RE0013, (If required).
4. Check the attached D-ring for the following:
  - a. Corrosion.
  - b. Damage.
  - c. Security of attachment.
5. Inspect the waist/chest buckles for proper operation.
6. Inspect required PFD markings for legibility.
7. Remove PFD from service if any discrepancies in Steps [2 A 4.](#) through [2 A 6.](#) are noted.
  - a. Send PFD to repair facility if repair cost does not exceed the replacement cost.
  - b. Replace PFD, P/N: MD3183-22, if repair cost exceeds the replacement cost.
8. Check PFD accessory pockets for the following:
  - a. Cuts.
  - b. Tears.
  - c. Operability of slide fasteners.

*NOTE: Black (BK) pouches are authorized for DSF personnel only.*

- d. Replace accessory pocket(s), P/N: MA6000-BK, or, P/N: MA6000-OR, if any of the above discrepancies are noted.
9. Inspect unit serial number marking on the yellow portion of the right inflation cell for legibility.
  - a. Restore serial number marking, (If required).
10. Inspect inflator assembly for the following, (Refer to [Figure 7](#)):

*NOTE: If plastic cover over actuator is missing or damaged, the PFD is still serviceable.*

- a. Damage.
    - b. Lanyard fraying.
    - c. Expiration.
    - d. Green indicator light.
11. Replace inflator assembly if any of the above discrepancies are noted, (Refer to Steps [3 A 1.](#) through [3 A 5.](#)).

## **B LEAK TEST PFD**

1. Manually inflate PFD.
  - a. Unzip both PFD zippers.
  - b. Inflate the PFD until firm through the oral inflation tube, (Refer to [Figure 8](#)).



**WARNING**

**AVOID EYE CONTACT, INHALATION, AND PROLONGED SKIN CONTACT WITH LEAK TEST COMPOUND. USE IN A WELL VENTILATED AREA. FAILURE TO COMPLY MAY RESULT IN PERSONAL INJURY.**

2. Apply leak test compound, P/N: MIL-PRF-25567E, to the oral inflation tube and the CO2 inflation valve.

**CAUTION**

**DO NOT SUBMERGE THE PFD IN WATER TO CHECK FOR LEAKS.**

*NOTE: If leaks are present, the leaking area will begin bubbling or foaming within 5 seconds and continues for about 2 minutes.*

3. Inspect inflated PFD for signs of leakage.
4. Remove PFD from service, if leaks are found.
  - a. Check inflator assembly for proper installation, if leaks are found at the CO2 inflation valve, (Refer to [Figure 8](#)).
  - b. Reinstall inflator assembly if installed incorrectly, (Refer to [Figure 9](#)).
  - c. Leak test PFD, (Refer to Steps [2 B 1.](#) through [2 B 3.](#)).
  - d. Send PFD to repair facility, if leaks are found at any other location provided the repair cost does not exceed the replace cost.
  - e. Replace PFD, if the repair cost exceeds the replacement cost.

*NOTE: The PFD must be set aside, undisturbed, for 2 hours before proceeding.*

5. Inspect inflated PFD for signs of deflation or pressure loss after 2 hours.
6. Remove PFD from service if it shows loss of pressure.
  - a. Send PFD to repair facility, if under warranty or repair cost does not exceed the replace cost.
  - b. Replace PFD if repair cost exceeds replace cost.
7. Deflate PFD by inverting the oral tube dust cap, (Refer to [Figure 8](#)):

**CAUTION**

**TO PREVENT DAMAGE TO THE PFD, DO NOT WRING OR TWIST IT WHILE DEFLATING.**

8. Gently squeeze the inflated bladder until all air is expelled.
9. Pack PFD.
  - a. Fold PFD panels, (Refer to [Figure 10](#)).
  - b. Secure two-step zippers, (Refer to [Figure 11](#)).

**C INSPECT SURVIVAL EQUIPMENT AND PYROTECHNICS**

1. Inspect the following attached survival equipment and pyrotechnics, (Refer to MPC [KB0107.0](#) and MPC [KB0096.0](#)):
  - a. Signal whistle.
  - b. Strobe light.



- c. PLB.
  - d. Signal mirror.
  - e. MK-79 personal distress kit.
  - f. MK-124 smoke and illumination signal.
  - g. Survival knife.
2. Verify survival equipment is attached in the correct location, (Refer to [Figure 1](#)).
  3. Inspect lanyards attaching all survival equipment to the accessory pockets for the following:
    - a. Cuts or frays.

*NOTE: Finished length of line from knot to knot shall be 36 inches or greater.*
    - b. Correct length.
    - c. Security of lanyard attachment to equipment and accessory pocket.
  4. Replace or re-tie lanyards as required, (Refer to Steps [1 B 2.](#) through [1 B 5.b.](#)).
  5. Store, segregate, or dispose of hazardous materials IAW all applicable local, state, and federal regulations.
  6. Document any discrepancies in the MD 3183v22 Maintenance Log.



**3 5 YEAR MD 3183V22 INFLATOR ASSEMBLY REPLACEMENT**

REFERENCES:

NONE

TOOLS/TEST EQUIPMENT:

NONE

EXPENDABLES:

NONE

CONSUMABLES:

HIT Rearm Kit, 17g, P/N: MA0095v22, CAGE: 1CJ91, NIIN: N/A

**A REPLACE**

1. Lay out the PFD in a clean area, free of obstructions.
2. Remove inflator assembly, (Refer to [Figure 12](#)).
  - a. Hold the CO2 cylinder through the PFD fabric cover with one hand.
  - b. Insert the metal key from the re-arm kit between the black locking ring and the labeled yellow cap.
  - c. Turn key counterclockwise.
  - d. Turn the black locking ring counterclockwise.
  - e. Lift off the inflator cap.
  - f. Squeeze the PFD sealing ring to elongate for CO2 cylinder removal.
  - g. Remove the CO2 cylinder through the sealing ring.

*NOTE: Units may continue using the PFD with a 38 gram CO2 cylinder until the manufacturer has adequate stock of 17 gram CO2 cylinders. See [COMDT COGARD WASHINGTON DC Message 291526Z JUL 16](#).*

3. Install new inflator assembly, P/N: MA0095v22, (Refer to [Figure 9](#)).
  - a. Insert new CO2 cylinder pointing upwards into the PFD.
  - b. Hold the CO2 cylinder through the PFD fabric.
  - c. Position cap with water inlet valve to the right.
  - d. Press the cap firmly onto the CO2 cylinder sealing ring.
  - e. Turn the black locking ring clockwise, while pressing on the cap, into the locked position.
  - f. Pull on the cap to ensure it has locked onto the inflator body.
4. Snap the beaded manual inflation lanyard in place.
5. Leak test PFD, (Refer to Steps [2 B 1](#). through [2 B 9.b.](#)).
6. Document any discrepancies in the MD 3183v22 Maintenance Log.





Serial Number Location



Bowline with an Overhand Knot

**MD 3183V22 PFD**  
**Figure 1**





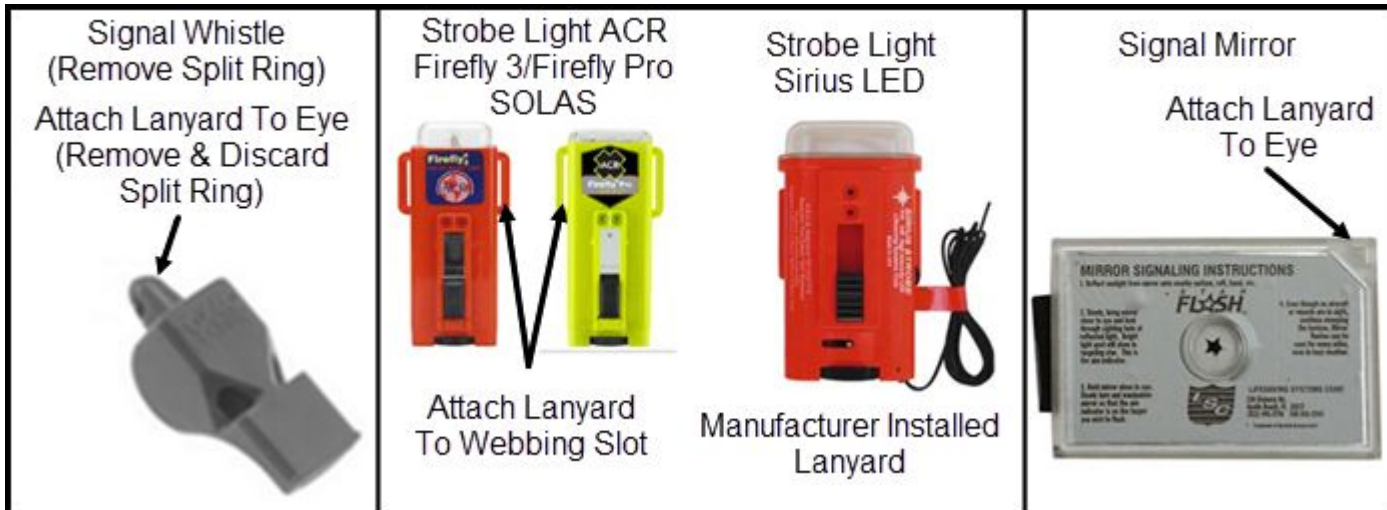

**SURVIVAL EQUIPMENT**

**Figure 2**



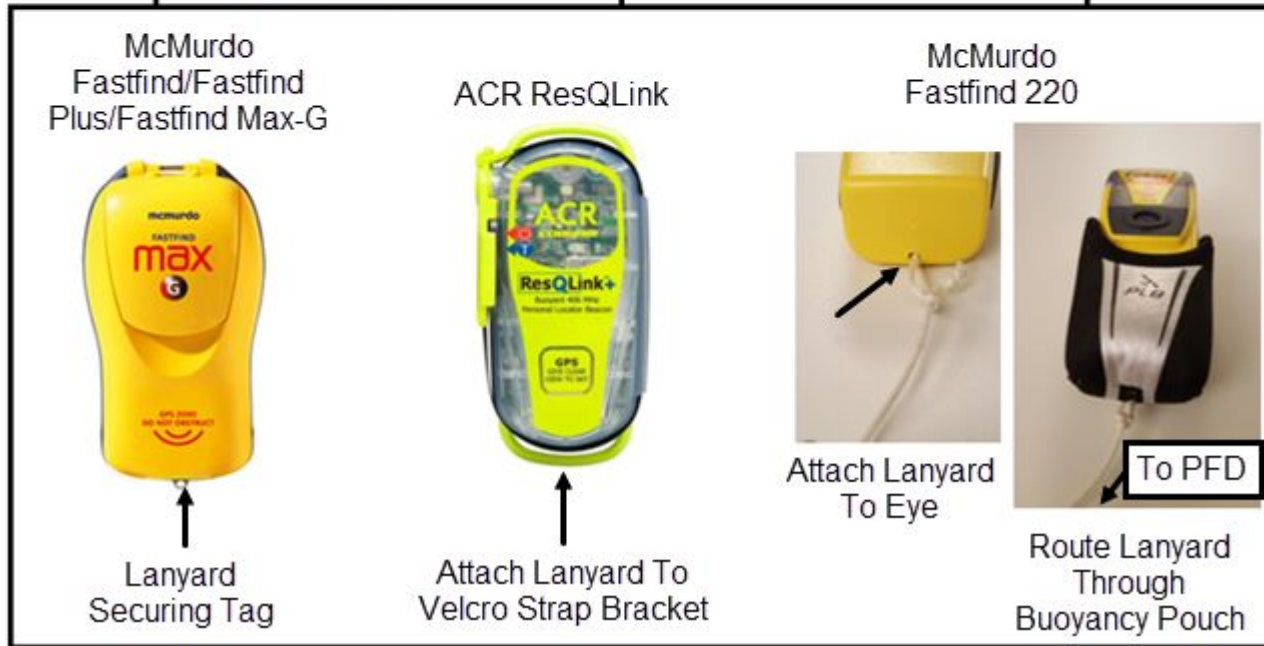
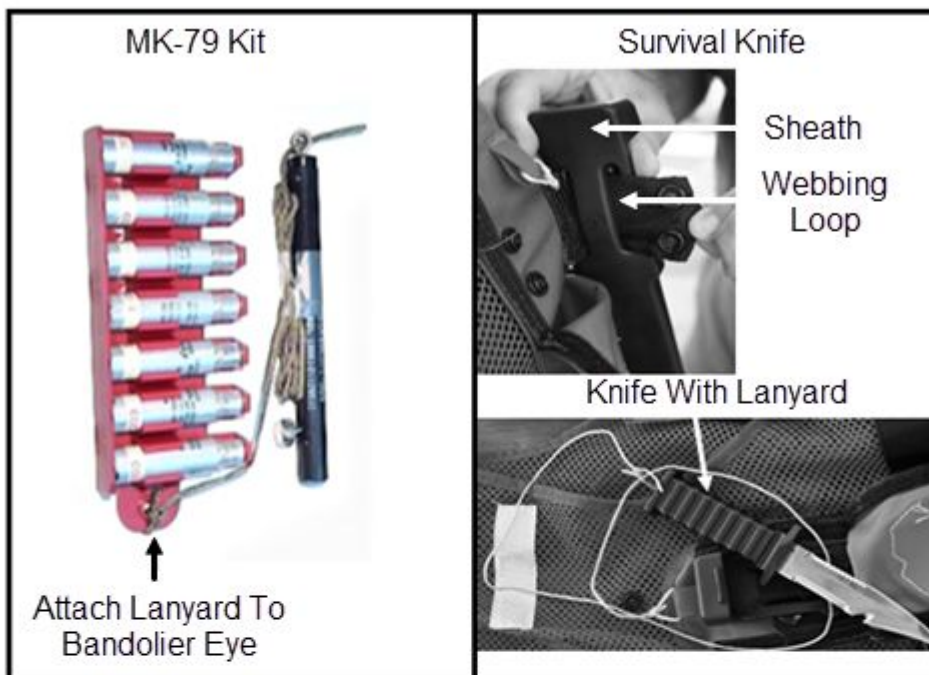



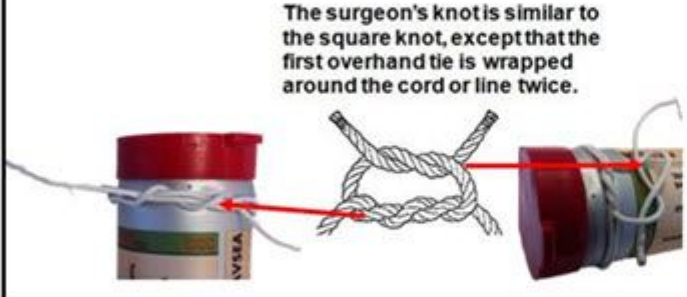

**SURVIVAL EQUIPMENT**

**Figure 3**

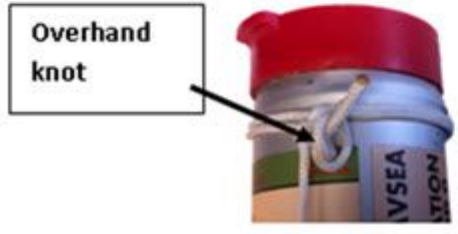

<p>1. Sear cut a piece of Type 1 Nylon cord to facilitate the retention harness tying process. (Cut approx. 72" long)</p>	<p>2. Wrap two turns of cord around the day end of the signal flare. (Leave approx. 2" of bitter end)</p> 
<p>3. Tie with a Surgeon's knot.</p> <p>The surgeon's knot is similar to the square knot, except that the first overhand tie is wrapped around the cord or line twice.</p> 	<p>4. Tighten the Surgeon's knot, keeping it flat and even.</p> 
<p>5. With the approx. 2" of bitter end, Tie an overhand knot to secure the Surgeon's. Sear cut this to prevent fraying</p> <p>Overhand knot</p> 	<p>6. Tighten down the overhand knot.</p> 

MK-124 RETENTION HARNESS STEPS 1-6

Figure 4



7. Route the remaining cord along the length of the signal to the opposite end.



8. Between the two raised beads of the night end, wrap two turns of cord around the signal.



9. Wrap the working end around both loops twice.



10. Take the bitter end and go under the line that stretched across the signal.



### MK-124 RETENTION HARNESS STEPS 7-10

Figure 5



11. With the working end, go through the loop that was just created, making an overhand knot.



12. Pull tightly



13. Tie an overhand knot to secure the first knot.



14. Tighten down the overhand knot and secure signal to vest.



**MK-124 RETENTION HARNESS STEPS 11-14**

**Figure 6**



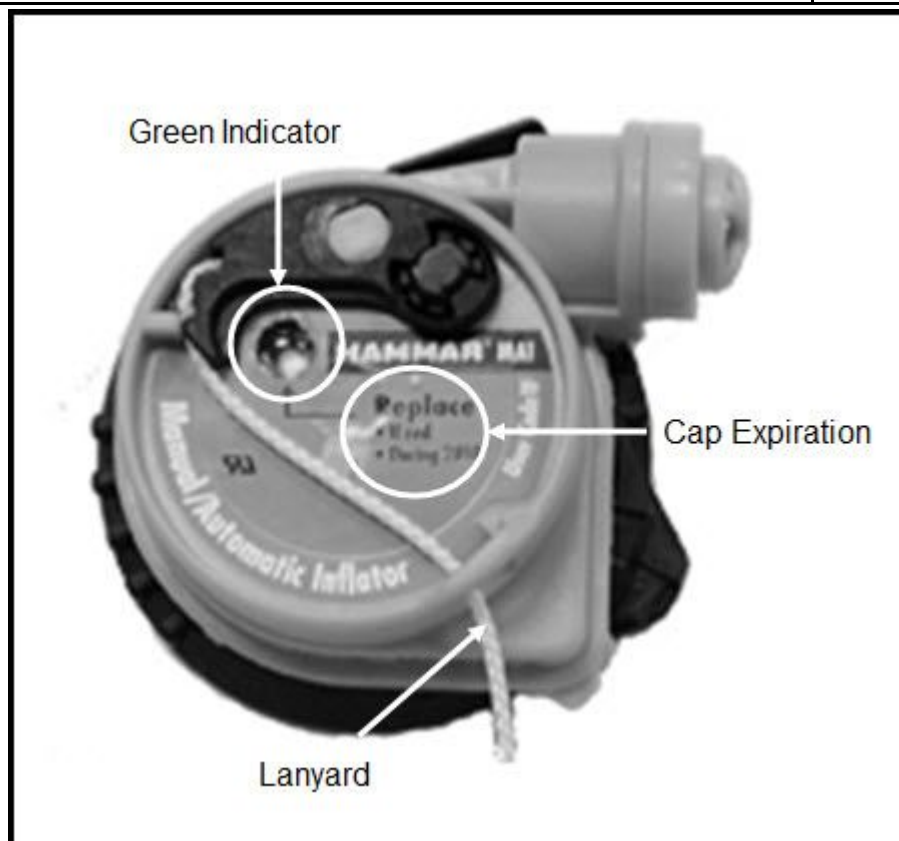

**INFLATOR ASSEMBLY**  
**Figure 7**



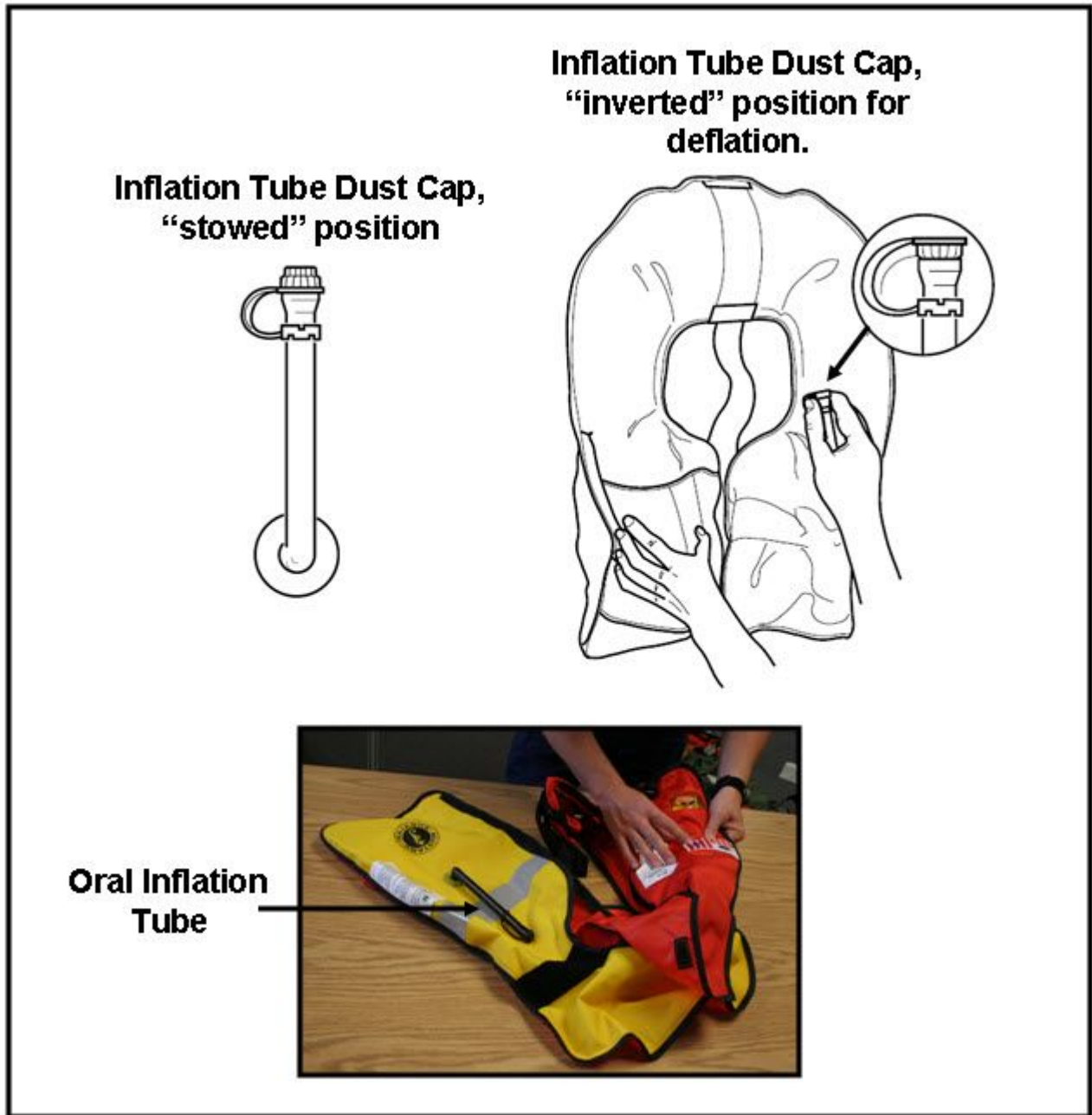

**ORAL INFLATION TUBE**

**Figure 8**



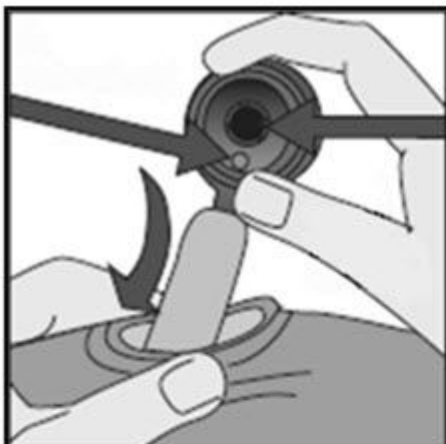

1. Check new inflator body for green indicator, then insert with cylinder point upwards into the PFD.



2. Check replacement cap for expiration date and green indicator.



3. Hold cylinder through fabric, position cap with inlet valve to the right.



4. Press cap firmly onto the inflator body and sealing ring.



5. While pressing firmly, turn black locking ring clockwise into the locked position.



6. Snap beaded inflation lanyard in place.

## INFLATION ASSEMBLY INSTALLATION

Figure 9





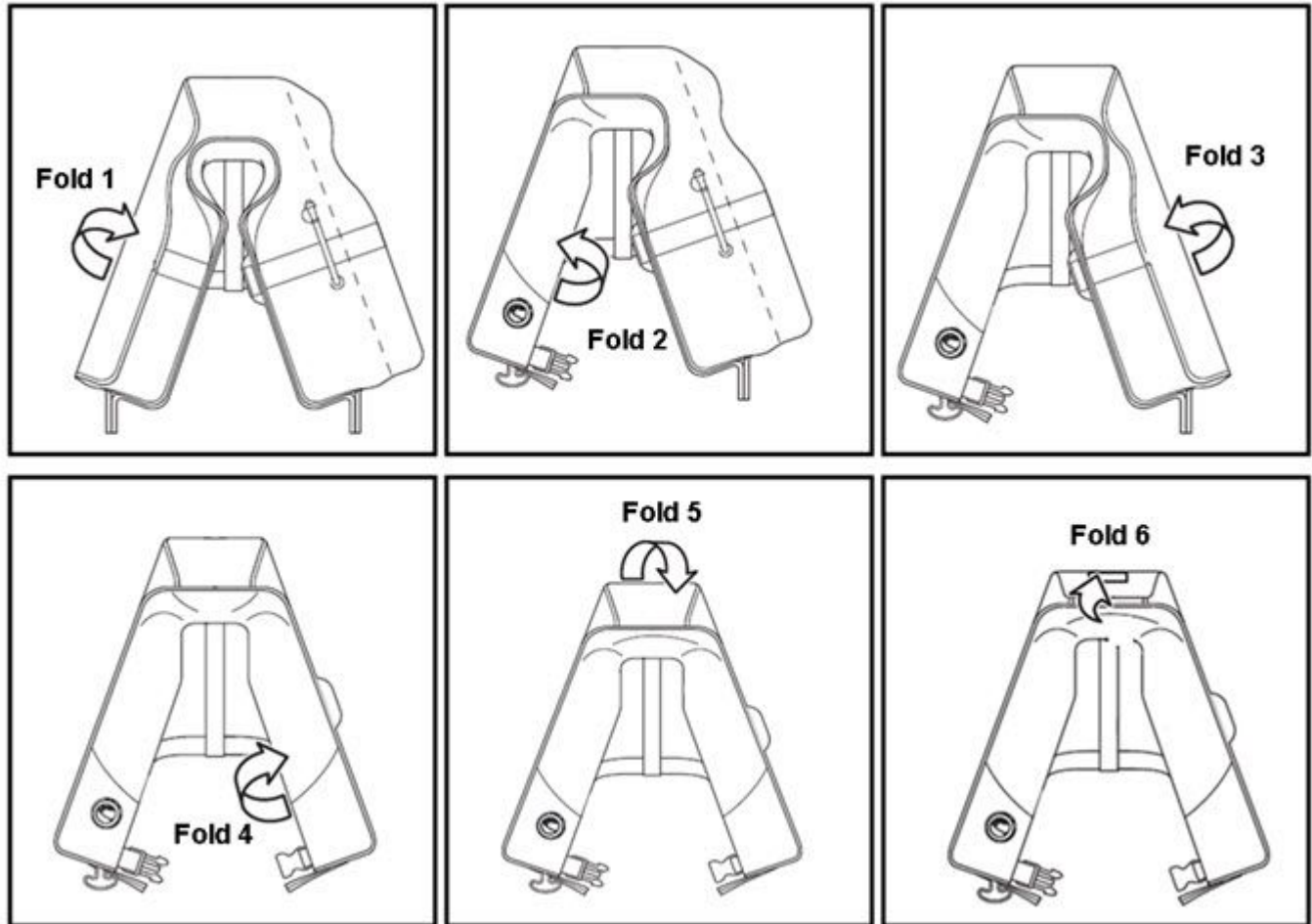

**RE-PACKING MD 3183V22**

**Figure 10**



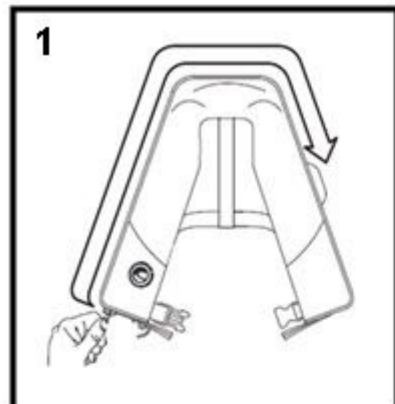

**1**  
Reset zipper 1 by pulling the slider around the top to the velcro tab.

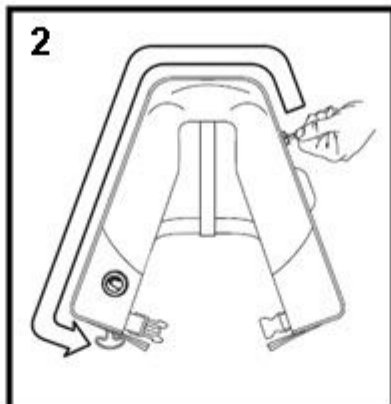

**2**  
Close zipper 1 by pulling the slider in the opposite direction to the end of the zipper.

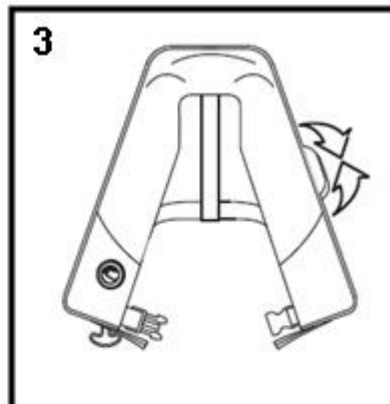

**3**  
Fasten velcro tab to keep the zipper closed.

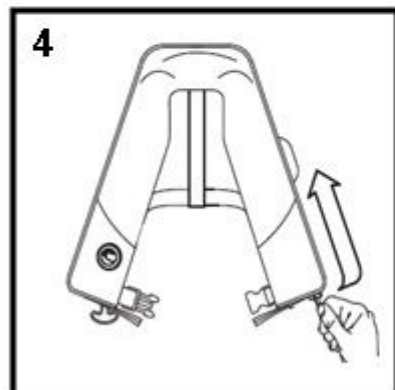

**4**  
Reset zipper 2 by pulling the slider to the velcro tab.

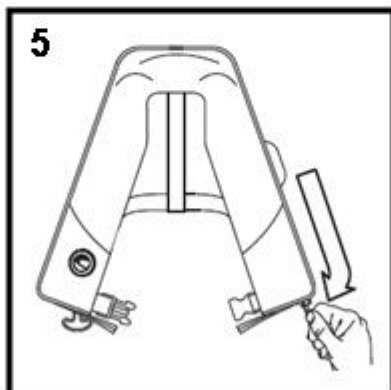

**5**  
Close zipper 2 by pulling the slider in the opposite direction to the end of the zipper.

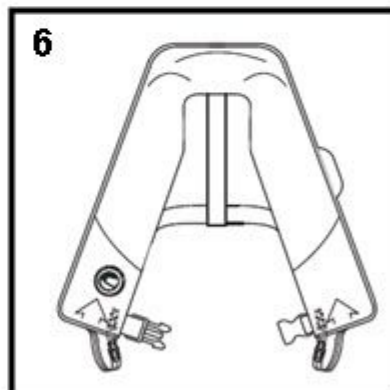

**6**  
Push the zipper ends into the openings at the bottom of the PFD.

### TWO-STEP ZIPPERS

Figure 11



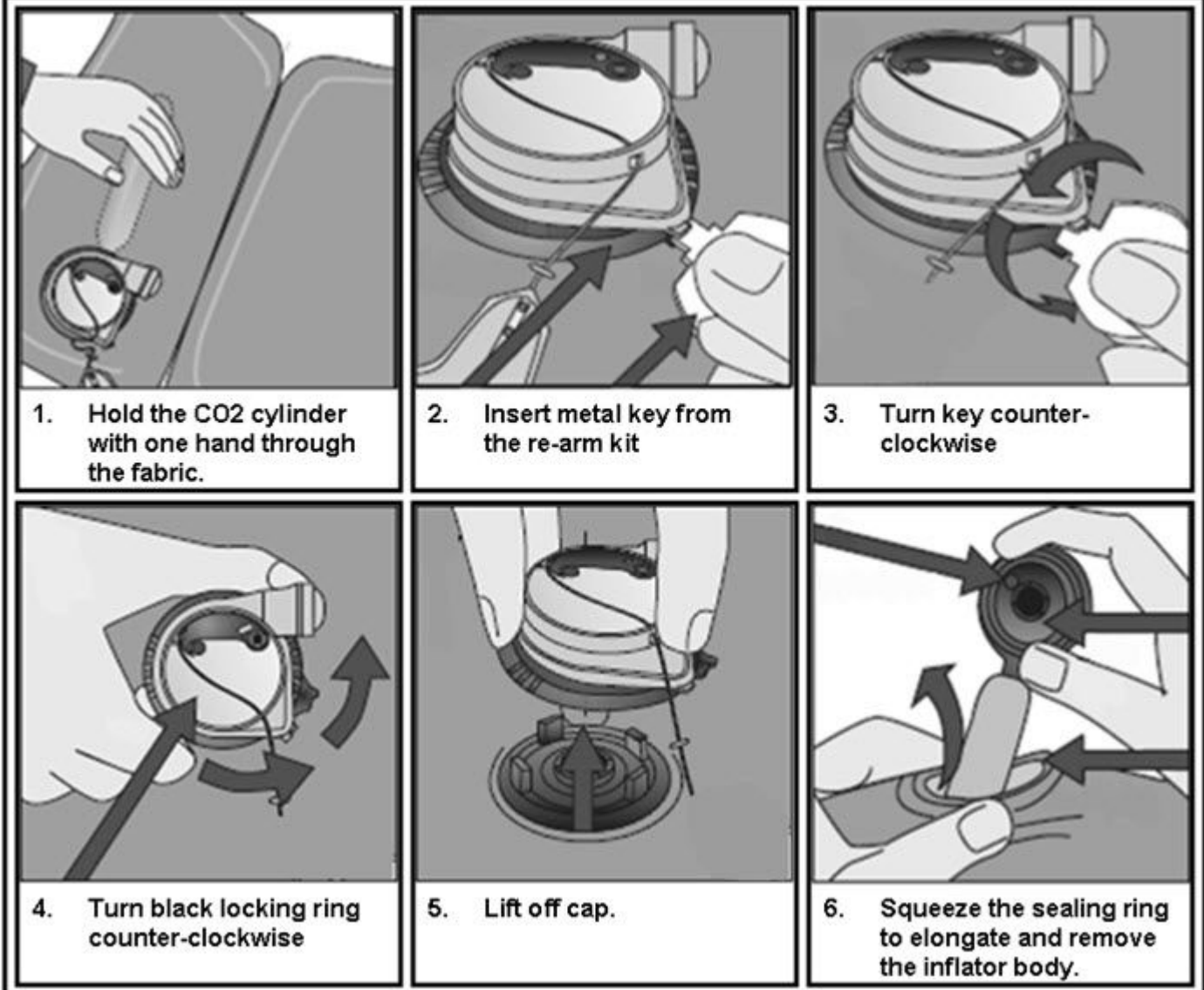

**INFLATION ASSEMBLY REMOVAL**

**Figure 12**

