



# Air Station Atlantic City Auxiliary Squadron Meeting

*Bob Quackenbush ADSO-AAC*

 August 15, 2023.

# Meeting Agenda



- A. Introduction from the ADSO
- B. Statistics & Sightings
- C. Aviation Issues & Actions
- D. Over the Horizon
- E. Forever Learning





# A. ADSO Introduction



## B. Statistics & Sightings

# In July, we were up to 10 completed flights and 36 hours flown. 4 MOMs, 5 RWAs, & 1 training flight.

11 canceled flights. Once due to lack of crew, 5 times due to weather.

## Log of ASAC Monthly Patrols no comments

As of 2023-08-03 15:54:37 Eastern Standard Time/EST • Generated by GARY STEVEN GOLDBERG • Sorted by Patrol Date (Ascending)

Patrol Type ↑	Status ↑	Patrol Date	Cancellation Reason	Total U/W Hours	Operator	Patrol Area	
01A: MARITIME OBSERVATION (MOM)	Submitted	7/3/2023		2.35	GARY STEVEN GOLDBERG	Chesapeake Bay	
		7/15/2023		3	CHARLES HANFORD BROWNING JR		
		7/22/2023		4.25	CHARLES HANFORD BROWNING JR		
		7/23/2023		0.3	GARY STEVEN GOLDBERG	Baltimore to Easton	
		7/30/2023		3.25	GARY STEVEN GOLDBERG	upper Chesapeake Bay	
	Denied	7/6/2023			GARY STEVEN GOLDBERG	Chesapeake Bay	
		7/21/2023			GARY STEVEN GOLDBERG	Baltimore to Easton	
	Cancelled	7/5/2023	Weather		GARY STEVEN GOLDBERG	Chesapeake Bay	
		7/9/2023	Weather		GARY STEVEN GOLDBERG	Chesapeake Bay	
		7/11/2023	Weather		GARY STEVEN GOLDBERG	Chesapeake Bay	
		7/16/2023	Weather		GARY STEVEN GOLDBERG	Chesapeake Bay	
	22A: OPERATIONS TRAINING (QUALS) (TRNQUALS)	Submitted	7/31/2023		3.33	JUDITH ANN REDLAWSK	Del River Training Qual Air Crew Tom Callahan
		Cancelled	7/20/2023	Insufficient Crew		CHARLES HANFORD BROWNING JR	
7/25/2023			Other		JUDITH ANN REDLAWSK	Training qual for new Observer Pilot 5th North	
55A: AIR-VESSEL INTERCEPT (INTERCEPT)	Submitted	7/6/2023		3	CHARLES HANFORD BROWNING JR		
		7/13/2023		2.7	GARY STEVEN GOLDBERG	ASAC	
		7/21/2023		4.75	JUDITH ANN REDLAWSK	RWAI	
		7/27/2023		4.3	GARY STEVEN GOLDBERG	KACY	
		7/28/2023		5	CHARLES HANFORD BROWNING JR		
	Cancelled	7/7/2023	Cancelled by OIA		GARY STEVEN GOLDBERG	ASAC	
		7/14/2023	Weather		CHARLES HANFORD BROWNING JR		
		7/20/2023	Cancelled by OIA		CHARLES HANFORD BROWNING JR		
		7/28/2023	Other		GARY STEVEN GOLDBERG	KACY	
Total	Sum			36.23			
	Count	23					



# Sightings - Items of Interest

*The Chesapeake is the greatest estuary on the planet. There is always something to see...*

- **Do you monitor 121.5?** Confirmed with Potomac Tracon the activation of an emergency beacon IVO Baltimore harbor.
- **Is traffic better viewed on iPads or Windows?** ADSB reported a beacon 200' below ground level. Mark One Eyeballs and Window combination differed. *Picture right.*
- **Connected to the Cloud?** Charles Browning had the opportunity to practice some actual IFR on a return flight from ACY.
- **Go topless on a hot day?** On a hot day, a convertible rocks! The USCGC interceptor could only open its doors; and only after we slowed to 80 kts.



*... if you take the time to look!!!*

# Airstation Atlantic City celebrated its 25th anniversary. Commemorative patches are available.

*Article found in sitrep 2-23 of Pterogram. To be mailed with meeting minutes.*



Fifth District Auxiliaries and CDR Chad Morgan - 5NR DIRAUX are 'Always Ready' to support active duty Coast Guard units.

District 5NR Auxiliaries, renowned for their unwavering support and commitment to the CG's mission, were proud to stand alongside their CG counterparts during this special celebration. These esteemed volunteers offered their assistance and expertise, further reinforcing the strong partnership between the CG and the Auxiliary. Their presence demonstrated the collaborative effort to ensure the safety and security of the maritime community. .... The event not only highlighted the commitment and dedication of the station's personnel but also underscored the invaluable contributions of District 5NR Auxiliaries. Their support and solidarity emphasize the Coast Guard's unwavering commitment to protect and serve the public.



**Can we talk AuxAir? Open House Volunteers welcome at Judy's airport. Her work jets will be on display. ... rumors say one will be the door prize.**

**Also, four prospects have contacted us. Let's make them welcome.**

[OPEN HOUSE 2023 - Capital City Airport \(flycxy.com\)](https://flycxy.com)

Steve Longenecker | Aux Air coordinator



The poster for the Capital City Airport Open House 2023 features a blue propeller logo on the left. The text reads: "CAPITAL CITY AIRPORT OPEN HOUSE" in blue and green, "HELICOPTER RIDES, AIRCRAFT DISPLAYS, FLIGHT SIMULATION, DRONES, FOOD TRUCKS, GIVEAWAYS, AND MORE!" in black, "AUGUST 19, 2023: 9AM-2PM" in large black letters, "BRING THE FAMILY TO CAPITAL CITY AIRPORT AND ENJOY A DAY ON THE AIRFIELD!" in blue, the website "WWW.FLYCXY.COM/OPENHOUSE" in green, and the "CCYV CAPITAL CITY AIRPORT" logo in blue and green at the bottom right.

- Andy Moore,
- Scott Sheldon,
- Steve Dykes
- Skip Reindollar





## Open House at Frederick Airport – 30 Sept

- Recruiting opportunity – pilots and facilities • Table plus 2 members (in addition to Bob Q)



Frederick Municipal Airport's  
*Frederick Festival of Flight*  
*Meet Your Airport*

**FREE ENTRY TO EVENT**  
Saturday, September 30th, 2023  
9:00 AM until 5:00 PM

Aircraft on Display | Aircraft Flyovers |  
Kids Activities | Local Vendors | Food Trucks



**FREDERICK  
MUNICIPAL AIRPORT**



# WE WANT YOU TO BE A DEDICATED VOLUNTEER PILOT IN THE U.S. COAST GUARD AUXILIARY(USCGA)



## U.S. Coast Guard



- We are looking for Private Pilots at Maryland Airports (Instrument Rating – even better!)
- We'd love you to offer your airplane for use as a USCGA facility and be reimbursed for all fuel and a maintenance stipend for USCGA flights
- Conduct Chesapeake Bay patrols in support of USCG Sector MD
- Fly intercept training missions with USCG Air Station Atlantic City crews
- Contact the USCG Auxiliary Sector



# C. Aviation Issues & Actions

# District Aviation Organization – Roles and Functions



## District Organization

Table 3-1 provides a standard organization for Auxiliary squadrons. Air units are authorized to make additions and deletions of functions and duties where necessary.

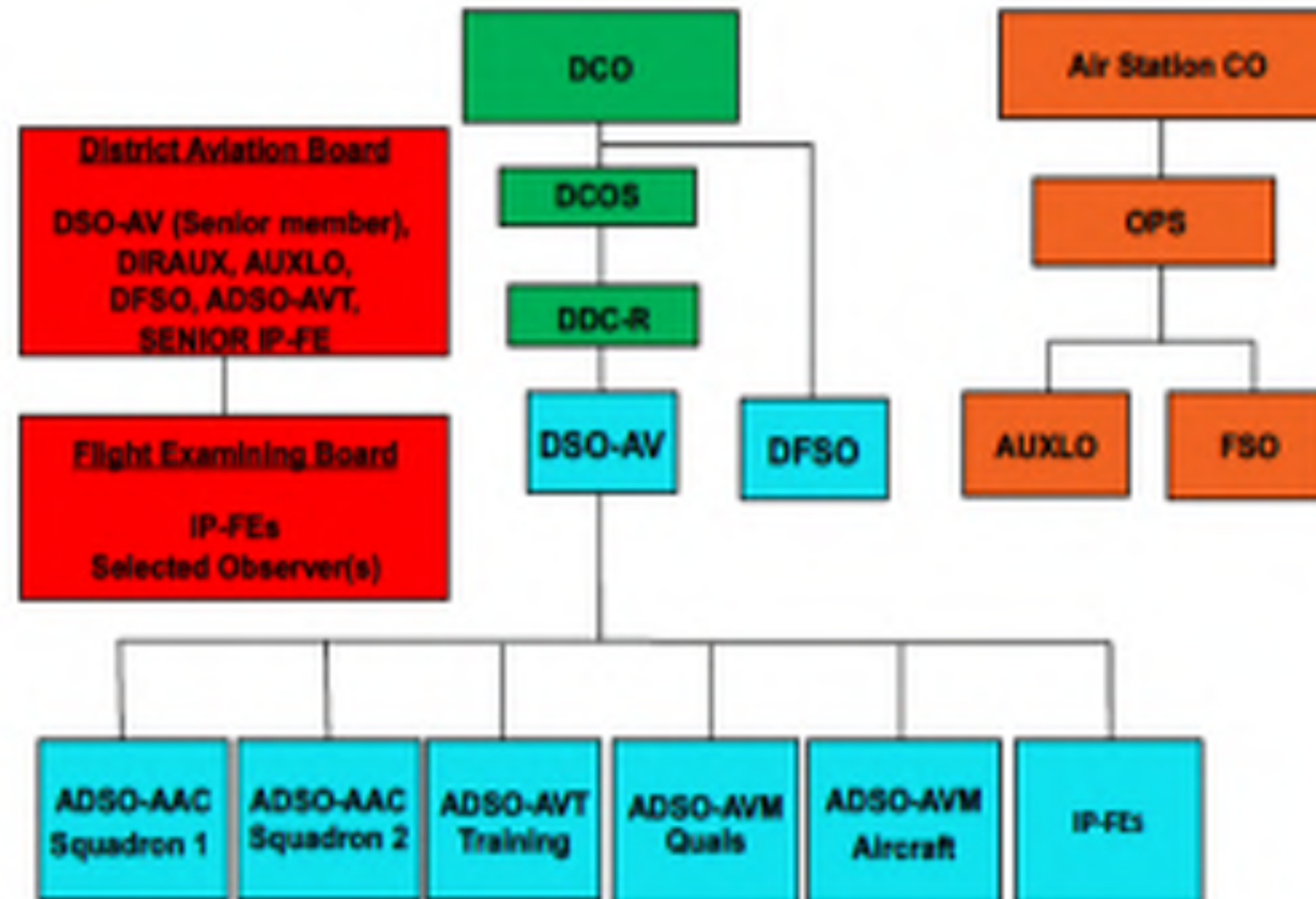

Table 3-1  
AUXAIR District Organization



# District Aviation Organization – Roles and Functions



## **C.5. District Staff Officer – Aviation (DSO-AV)**

District Staff Officer for Aviation (DSO-AV) is responsible to lead the district Auxiliary aviation program and function as the senior member of the District Aviation Board. The DSO-AV ensures effective support for the Air Station(s) and maintains a close liaison with Air Station Leadership.

## **C.6. Auxiliary Aviation Coordinator (AAC)**

Auxiliary Aviation Coordinator (AAC) functions as the squadron Operations Officer and leads the Auxiliary squadron's day to day flight operations. The AAC is a member of the District Aviation Board (DAB) and maintains a close liaison with the AUXLO and OPS.

## **C.7. District Flight Safety Officer (DFSO)**

District Flight Safety Officer (DFSO) implements the Aviation Safety Program within the District. Communicate details of the program to the divisions and flotillas with aircraft facilities. Advise the District Commodore (DCO) and DSO-AV on all aviation safety matters and shall report directly to the DCO. The DFSO promotes, monitors, and reports on safety matters and maintains a close liaison with the FSO.

## **C.8. Assistant District Staff Officer -Aviation Training (ADSO-AVT)**

Assistant District Staff Officer for Aviation Training (ADSO-AVT) functions as the Squadron Training Officer, oversees the District's aviation standardization and training program and is a member of the District Aviation Board.

## **C.9. Assistant District Staff Officer –Aviation Management (ADSO-AVM)**

Assistant District Staff Officer for Aviation Management (ADSO-AVM) functions as the Squadron Administrative Officer and is responsible to implement the district/squadron's process to record and track flight crewmember's and aircraft facility records. Work closely with the ADSO-AVT to support the district's aviation standardization and training program. Districts/squadrons may appoint multiple ADSO-AVMs



# **Curtis Bay is “desperately” seeking Sector watchstanders.**

***Good opportunity to see what sector does and to promote the air program...***

## **What does a Watch Stander do?**

- Answer the phones - contact with general public and Coast Guard members
- Answer VHF radio transmissions.
- Maintain radio contact with all Coast Guard and Coast Guard Auxiliary units in the area.
- Control entry to the Coast Guard Station
- Maintain an accurate log of all events while on the watch.

## **How do you become a Watch Stander?**

- Pass an AOR (Area of Responsibility) test on local charts.
- Complete the Communication Watch Stander Qualification Guide (PQS).
- Take the Introduction to Risk Management class available on the [Auxiliary Learning Web Site](#).
- The 4 Hour TCT refresher is required every year.
- Pass a qualification board. Note - *the PQS and process is exactly the same for Auxiliary members as it is for Active Duty.*

***... contact John Fewer, our sector liaison, if interested.***



# Why do we care what Sector does? They are our customer!

***The Air Station owns the aviation assets. But generally, Sector owns the missions.***

Our Squadron, with J Fewer's help, is working to establish a closer Sector relationship...

- On Thursday, we are taking John and his Auxlo (Bosun Motta) on a AOR Familiarization flight.
- The new Sector Deputy, CDR Caren Damon and her number 2, LCDR Kate Newkirk plan to take a similar flight later this month.
- Sector department heads and command center personnel will likely follow this year focusing on their specialties.

*.... our goal is to have more frequent Sector participation in our missions so we can better understand their needs. And they can better appreciate our capabilities.*

**For a complete list of missions , see Operations Process Guide Volume II, Air Operations:**

- Ice Patrol
- ATON
- Pollution Response
- Marine Safety
- Regatta Support
- Waterway Management
- Wildlife Management
- Etc.



**Have you been kicked in the REYRS? There's an app for that.**

## **Finding your REYR**

**Using AuxData 2 (AD2)**



# Step 1 - Find your Member Record and select RELATED tab

<https://uscg.experience.crmforce.mil/auxcommunity/login>

uscg.experience.crmforce.mil/auxcommunity/s/contact/003t000000TjxqRAAR/ [REDACTED]

Home Members Units Activity Logs Member Activities More ▾

Search...

Member [REDACTED] + Follow Edit

Unit Name	Unit Number	Member Status	Boating Safety Course Completed
<u>TWO GAITHERSBURG</u>	0542404	BQ	<input checked="" type="checkbox"/>

**DETAIL** **RELATED** SKILLS AND AVAILABILITY PPE CHATTER

**International**

**Member ID**  
[REDACTED]

**Name**  
[REDACTED]

**Unit Name**  
TWO GAITHERSBURG

**Unit Number**  
0542404

**Occupation**

**Vendor Site Id**

**Vendor Number**  
190463

**Vendor Name**  
[REDACTED]

**Education Level**

**Total Inactive Duration**  
0

**Total Active Duration Plus Today**  
4,224

**Total Inactive Duration Plus Today**  
0

**Total Active Time IN**  
11 Years 6 Months 29 Days

**Total Time OUT**

**Member Status**  
BQ

**Member Status Date**  
8/28/2013

**Archived**

**Boating Safety Course Completed**

**Spouse Name**  
[REDACTED]

**Travel**

**Advance Notice**

**Activity Log Approver**

**PPE Manager**

**Initial Enrollment Date**  
1/20/2012

**Flotilla Date**  
1/20/2012



# Step 2- Select Competencies Section

uscg.experience.crmforce.mil/auxcommunity/s/contact/003t000000TjxqRAAR...

Home Members Units Activity Logs Member Activities More

Member [REDACTED] + Follow Edit

Unit Name: TWO GAITHERSBURG | Unit Number: 0542404 | Member Status: BQ | Boating Safety Course Completed:

DETAIL RELATED SKILLS AND AVAILABILITY PPE CHATTER

### Member Status History (2)

Member History Record Number	Status	Status Date	Status End Date
MH-186318	AP	1/20/2012	8/28/2013
MH-198312	BQ	8/28/2013	

View All

### Member Activities (6+)

Member Activity: Member Activity Record Nu...	Activity Record Number	Review Status	Mission Start Time
MA-10790247	AL-6878094	Approved	8/9/2023 14:32
MA-10790240	AL-6878090	Approved	8/9/2023 12:45
MA-10790237	AL-6878089	Approved	8/9/2023 08:17
MA-10790235	AL-6878087	Approved	8/9/2023 06:40
MA-10790232	AL-6878085	Approved	8/9/2023 06:00
MA-10783418	AL-6874032	Approved	8/6/2023 09:15

View All

### Competencies (3)

Member Competency Record Number	Competency Type	Status	Original Certification Date
MC-172782	AUXCT - CORE TRAINING	Certified	4/30/2016
MC-180719	AIR CREW	REYR	2/17/2017
MC-220401	BASIC QUALIFICATION COURSE II	Not Certified - Trainee	9/26/2019

View All



# Step 3 - Select MC record that indicates REYR



Members > [Redacted] > Competencies

3 items - Updated a few seconds ago

Member Competency Rec...	Competency Type	Status	Original Certification Date	REYR Start Date
1 MC-172782	AUXCT - CORE TRAINING	Certified	4/30/2016	
2 MC-180719	AIR CREW	REYR	2/17/2017	4/13/2020
3 MC-220401	BASIC QUALIFICATION COURSE II	Not Certified - Trainee	9/26/2019	

Click MC record number to bring up more detail



# Step 4 - View MC Record for clues

uscg.experience.crmforce.mil/auxcommunity/s/member-competency/a1R10000002k6JNEAY/mc180719

Home Members Units Activity Logs Member Activities More

Member Competency MC-180719

Member Competency Record Number MC-180719

Member [REDACTED]

Original Certification Date 2/17/2017

Competency Category AIR

Competency Type AIR CREW

Status REYR

Status Assigned Date 2/17/2017

Night Certified

Comments [REDACTED]

Recertification/ Expiration Date

REYR Start Date 4/13/2020

Created By Jose Agrelot, 4/13/2020 12:52

Last Modified By Admin User 42, 7/27/2022 07:33

Tasks (6+)

Member ...	Task Type	Status	Complete...
MCT-1144...	AUXILIARY CREW RESOURCE MGMT (CRM) / OPS RISK MGMT (ORM) (AUX-17)	Completed	7/16/2023
MCT-1144...	CRM REFRESHER	Completed	7/16/2023
MCT-1129...	CRM REFRESHER	Archived	4/29/2023
MCT-1129...	(AIR) EMERGENCY EGRESS TRAINING	Completed	4/29/2023
MCT-1129...	(AIR) CGAS WORKSHOP	Completed	4/29/2023
MCT-1067...	(AIR) EMERGENCY EGRESS TRAINING	Archived	4/23/2022

View All

Files (0)

Title	Owner	Last Modified	Size
-------	-------	---------------	------

View All

Member Competency History (1)

Date	Field	User	Original...	New Va...
7/27/2...	Original...	Admin ...		2017-02...

View All

Justification for REYR sometimes noted here



# Can I fly if I'm in REYR? *That's Complicated.*

## Not in REYR

1. Armstrong, Charles
2. Babcock, Lee
3. Blackford, Bob
4. Brown, Brandon
5. Browning Charles
6. Goldberg, Gary
7. Kirchner, Karl
8. Klein, Steve
9. Kripas, Ron
10. Gonzalo, Laje
11. Quackenbush, Bob
12. Redlawsk, Judy
13. Sheehan, Joe
14. Talepour, Ali
15. Van Netten, Jeff
16. Zimmerman, Kimberle

1. New Guidance has just been published describing REYR.
2. We are still digesting it. In some case, you are grounded. In others, your status is downgraded. For example, pilot downgraded to aircrew; or aircrew to “trainee”.
3. For the time being, the flight status of anyone in REYR will be determined by the DSO-AV (Jim McKeever).

## Process for REYR removal?

1. Better not to go into REYR in the first place. Take your classes early.
2. If you are in REYR - talk to Bob Quackenbush





# D. Over the Horizon

# Summer is coming to a close, but there are still ample opportunities to help yourself, and to help the Squadron.

- **Swim Scheduled**

  - Sector MD: Monday, 28 August at 1900 at Westleigh Swim Club, 14900 Dufief Mill Road, North Potomac, MD.

- **Aux-17 update.** FY 2024 schedule not yet out. Many people need to take Aux-17 but space will be limited. Sign up as soon as you can.
- **September Missions will soon be scheduled.** The Google Survey form is now the preferred method of communicating your availability. Its advised that you also contact the aircraft commander directly for days when you are not scheduled.
- **Field Day needs to be planned.** Volunteers? We would like to view distress items (streamers, “Oscar”) from various altitudes.
- **Future of Squadron Meetings.** Frequency? Location?

*BTW, we are in the middle of the boating season and the bay is busy. Time to Fly.*



# The Auxiliary has updated many of its manuals.

***We are currently digesting the updates. But many changes anticipate “Project Raven”.***

<https://wow.uscgaux.info/content.php?unit=BX-GROUP&category=guides-and-handbooks>

Document #	DATE	SUBJECT	VERSION	TYPE
16798.31A	1-Aug-2023	<u>Auxiliary Operations Process Guide-Volume I-General/Surface</u>	1	Guide
16798.32A	1-Aug-2023	<u>Auxiliary Operations Process Guide-Volume II-Air Operations</u>	1	Guide
16798.33A	1-Aug-2023	<u>Auxiliary Operations Process Guide-Volume III-Telecommunications</u>	1	Guide
16798.34A	1-Aug-2023	<u>Auxiliary Operations Process Guide-Volume IV-Marine Safety and Security</u>	1	Guide
16798.5A	1-Aug-2023	<u>Auxiliary Training Handbook-Aviation</u>	1	Handbook





**The new Training & Operations manuals are directing us to practice and maintain skills...**

**More to Come ..... Stay Tuned.**

***... this is consistent with our new Project Raven.***



# Our Squadron Project needs a name, and we need to move forward to **Step 2: listing ideas and actions for Project Objectives.**

**Project Name:** The name Project Raven has been proposed. A bird associated with intelligence, lost souls, and the State of Maryland. **Any other suggestions?**

## **Project Mission Statement [proposed]:**

We want the the U.S. Coast Guard to regard us as a valuable and dependable partner, reliably supplying competent and skilled resources to successfully achieve its Auxiliary permitted missions, on demand, and whenever scheduled.

## **Project Objectives [proposed]:**

- A. Recruit & Retain qualified facilities and crew
- B. Develop & Maintain the next level of mission critical skills. The AuxAir observer syllabus is the bare minimum. We want our crews to perform at a higher level.
- C. Instill and encourage a culture of *Operational Excellence*
- D. Market our services through a reputation for professionalism



Nunquam Paratus - *Nevermore*



# How can our program be better? Have an idea? Let us know.

*Only 2 people have submitted committee ideas. Really? Help us out...*

## **A. Goals - Recruit & Retain**

1. Recruit certified aircraft
2. Recruit aviation oriented crew prioritizing future aircraft ownership, and diversity
  - A. Internal recruiting (Aux surface side; retiring Gold side crews)
  - B. External recruiting
3. Retain 1st year members by simplifying the initial transition (uniforms, forms, procedures)
4. Retain 1st year members by making it faster, easier & less confusing to satisfy their observer training
5. Retain certified members by increasing their sense of achievement and interest

## **B. Goals - Mission Skills** (next level - beyond the syllabus)

1. AOR Familiarization Skills (what is Gold side interested in seeing?)
2. Ice Patrol
3. MOM Skills (SAR, Maritime Awareness (environment, sea state), Intel)
4. Photographic Skills (working onboard camera)
5. RWAI Skills (Pilot Skills, Radio Skills, Aircrew skills)



# Send Helen Gemignani your input for A-D sub-goals.

*Soon we'll have a hybrid meeting to flesh out, and to prioritize.*

## **C. Goals - Operational Excellence (Pilot & Observer Currency )**

1. Assess & Improve mission performance
2. Develop and Execute Currency exercises (ground)
3. Develop and Execute Currency exercises (air)

## **D. Goals - Market & Reputation**

1. Introduce our services to all Stakeholders (Sector, Air station, Boat Station, State & Local government)
2. Promote our services through articles, newsletters, blah, blah (see Como G efforts) flying clubs, AOPA, EAA chapters, Special Interest (IFR club)
3. Establish relationships with D5S leadership to promote the air program

Place your input here:

For example, what would go under D - Market & Reputations?

(Need 5 items to continue to next slide)





# E. Forever Learning

# Ray's Corner



Ancient Order of the Pterodactyl



# Cleared For Departure ...



*... Frequency Change Approved.*