

Chapter 5

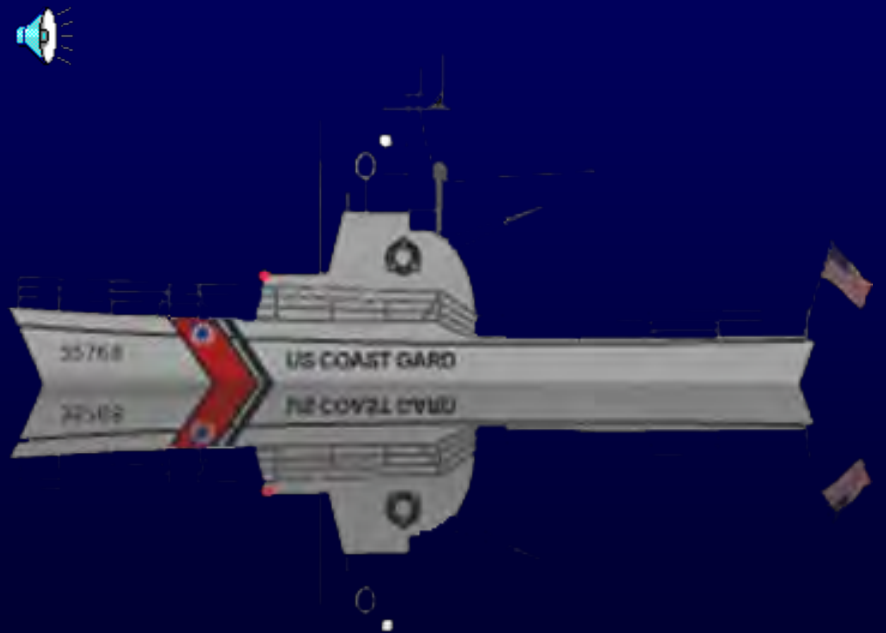

The Legal Requirements Of Boating





Legal Responsibility

- **Federal: United States Coast Guard**
 - Federal laws
 - Equipment requirements
 - Safety recommendations
- **Florida Supersedes Federal:**
 - West Coast out 9 nautical miles
 - East Coast out to 3 nautical miles
 - Additional equipment requirements (e.g. head)
 - Educational requirements (e.g. this course, details later)
 - Registration requirements-- Insurance not required but highly recommended





Decals and Numbering

- Numbering format AB 1234 CD
- 3" high "Block" style
- Contrasting color
- Annual decal
- Attach per instructions

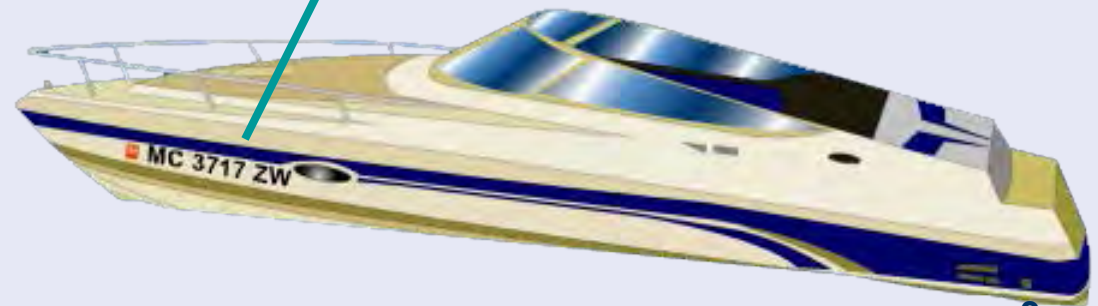
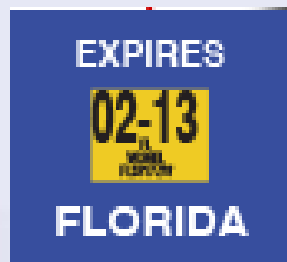



PWCs Need Decal





Registration

- **Registration Certificate (Original)**
 - Must be on board when underway
- **No other numbers forward of amidships**

| | | | | | | | | | |
|------------------------------------|----------------------|--------|-----------------|---------------|-------------------------------|----------------|-------|---------------|-----|
| FLORIDA VESSEL REGISTRATION | | | | CO/AGY 4 / 13 | T# 784834525 | | | | |
| | | | | | B# 4817587 | | | | |
| FL/DO # | FL7023LA | DECAL | 01915614 | Expires | Midnight Wed 1/21/2015 | | | | |
| YR/MK | 1999/HYDRAS | BODY | VS | TITLE | 79181706 | Reg. Tax | 34.25 | Class Code | 100 |
| HIN | HSXYC249E999 | | | FUEL | GAS | Init. Reg. | | Tax Months | 12 |
| HULL | FBGLSS | PROPUL | OUTBRD | LENGTH | 23'8" | County Fee | 16.13 | Back Tax Mos | 0 |
| USE | PLSRE | TYPE | OPEN | 2ND DL# | U142200429700 | Mail Fee | | Credit Class | |
| DL/FEID | U142660380210 | | | | | Sales Tax | | Credit Months | 0 |
| Date Issued | 1/6/2014 | | | | | Voluntary Fees | | | |
| | | | | | | Grand Total | 50.38 | | |





Title & Registering

- Boats must be registered and numbered within 30 days of purchase
- Out of state moves must be reported within 90 days into Florida
- Boats registered in another state have 90 days to register when used in Florida waters.





Documented Vessels

- U.S. Citizens only may have a large vessel documented: 5 or more net tons
(2 x Breadth x LOA X Depth x .67)/100 = net ton
- Documentation number must be permanently affixed in 3" high block-type Arabic numerals preceded with letters "NO." **clearly visible** on the interior integral structure of the vessel.
- Also, the NAME & HOME PORT 4" in height must be displayed together on hull (usually on the stern)





Hull Identification Numbers

- HIN unique number
- Engraved into transom fiberglass

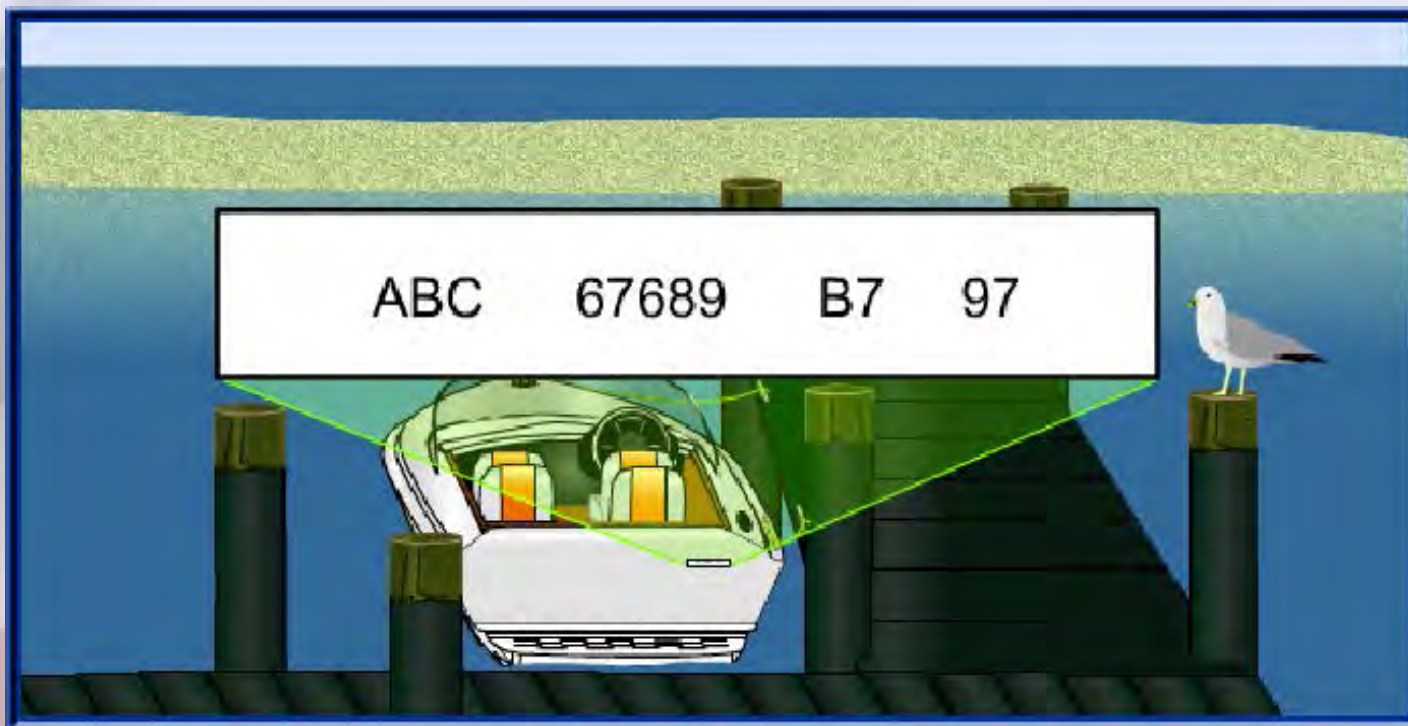



Operating PWC/Motorboat, 10hp or Greater

- **In Florida must be 14 to Operate;
18 to rent a PWC**
- **In Florida, you must be at least
18 years old to sign a contract to
rent a PWC**
- **Boat/PWC renter is responsible
for equipment and liable for
accidents**





Boater Education Requirements

Operators:

As of January 1, 2010 Florida Law states that a person born after January 1, 1999

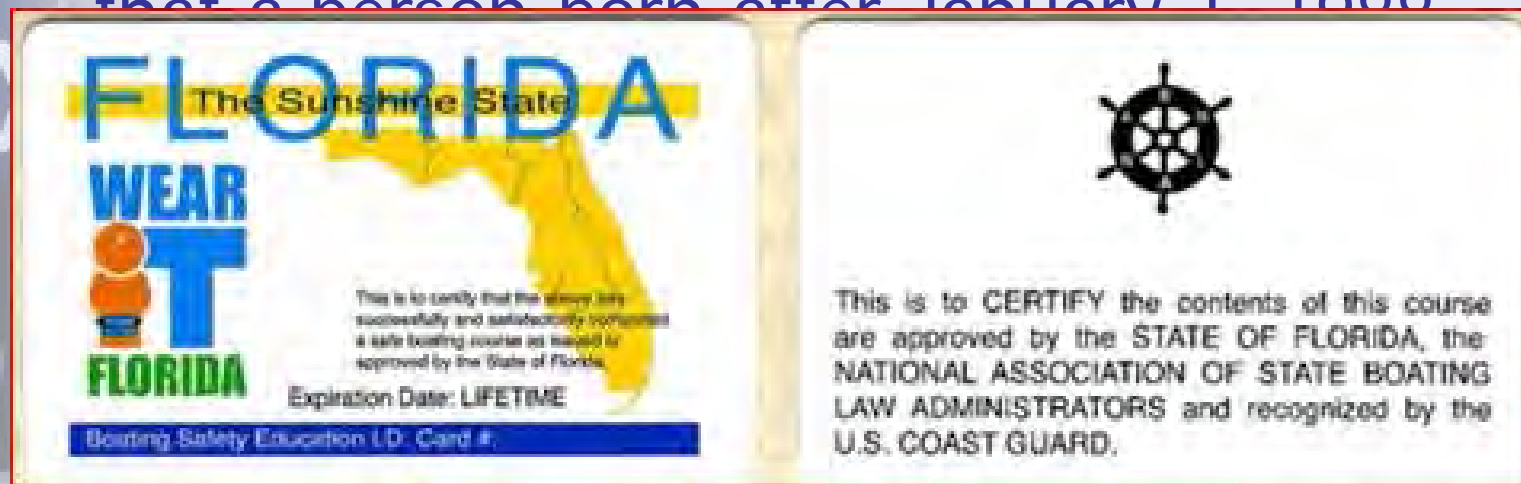

Safety Education I.D. Card and photographic identification card, Or.....





Boater Education Requirements

Operator, cont.

- Is accompanied onboard by a person who is exempt, or least 18 years old and possesses the required Boating Safety Education Identification Card, provided that person is attendant to and responsible for the safe operation of the vessel, or.....





Boater Education Requirements

Operator, cont.

- A non-resident who has in his or her possession proof that he or she has completed a NASBLA-approved boater safety course or equivalency examination from another state, or.....





Boater Education Requirements

Operator, cont.

- A person operating a vessel within 90 days after completing an approved boating safety course, and has a photographic I.D. and a boater education course completion certificate showing proof of having completed the required boating safety education course (including name, DOB, date of class completion).
(Effective October 1, 2011.)





Boater Education Requirements

Operator, cont.

- A person licensed by the U.S.C.G. as a master of a vessel is exempt from the educational requirement (Effective October 1, 2011.)



Beware Of Negligent Operation

- Operating in restricted areas
- Wake jumping, hull leaves water
- Failure to regulate speed: Wake Damage
- Operating while under the influence of Alcohol
- Bow riding, or riding on
• seatback, gunwale, or transom.
- (FL pg. 29, Fed pg. 47)





Alcohol and Drugs

- Use causes impaired balance, blurred vision, poor coordination, and impaired judgment
- Under age of 21 In Florida **.02% bac illegal**
- Standard for BUI : **0.08% bac**
- Civil penalty: up to \$1000 fine
- Criminal penalty: up to \$5,500 or 1 year imprisonment, or both





Obstructing Navigation

- **It is illegal to:**
 - Anchor in a channel
 - Tie up to a buoy or other ATON
 - Tamper with, deface, or move any ATON
 - Obstruct a pier, wharf, boat ramp





- Do not approach within 100 yds. and slow to minimum speed within 500 yds. of Naval Vessel.
- Avoid all security zones
- Do not stop or anchor beneath bridges





Personal Flotation Devices

- **One Life Jacket for every passenger, readily accessible**
- **Inflatables only for persons older than 16**
- **Life Jackets must be in good condition and readily available**





Personal Flotation Devices

- In Florida, children under the age of 6, while cruising on any boat less than 26 feet in length must wear a Type I, II, or III USCG approved PFD when underway.
- Federal law requires anyone under 13 to wear a life jacket while on deck when underway.





Type I: Offshore Life Jacket

Minimum
Buoyancy
22 pounds



Type II: Near-Shore Vest



Minimum
Buoyancy
15.5 pounds



Type III: Flotation Aid



Minimum
Buoyancy
15.5 pounds



Type III/IV: Inflatable PFD



Minimum
Buoyancy
22 pounds

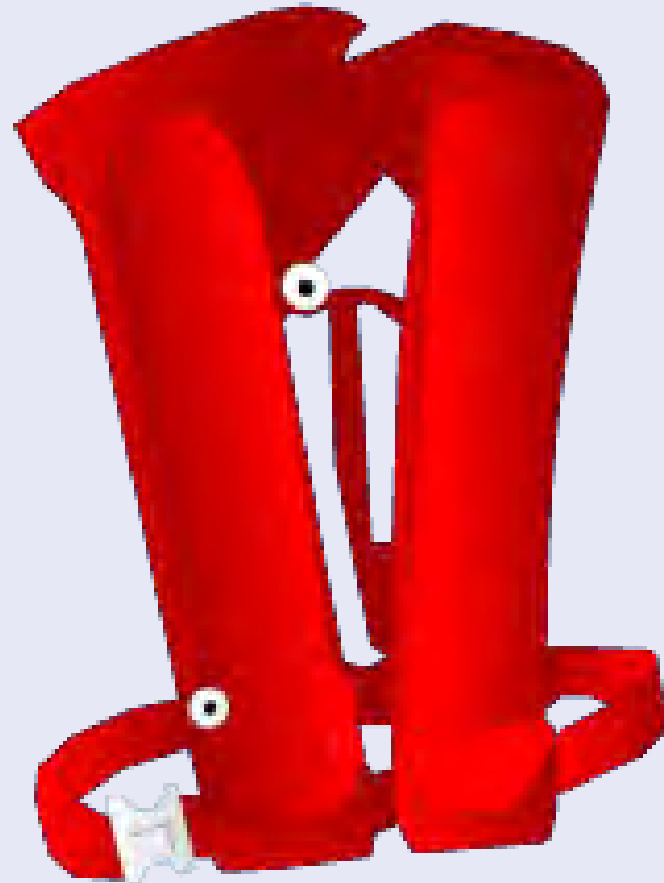



Type IV: Throwable Device

Must have one on board if =>
16'





Type V: Special-Use Device





Types Of Fires



**Trash Wood
Paper**



**Liquids
Grease**



**Electrical
Equipment**





Fire Extinguishers

- Required to be on all vessels where a fire hazard could be expected from engines or fuel system.
- However, highly recommended to be carried aboard all vessels.





Fire Extinguishers

- **Dry chemical most common for marine use**
- **Inspect and gently shake regularly**
- **Type B required onboard**
 - Inboard or I/O engines
 - Permanently installed fuel tanks
 - Closed living spaces
 - Closed compartments where portable fuel tanks are stored





Charge Indicators



Fire extinguishers on pleasure craft must have pressure dials. Push button indicators are no longer acceptable





Backfire Flame Arrestor

- Required on gasoline engines installed after April 25, 1940, except outboard motors

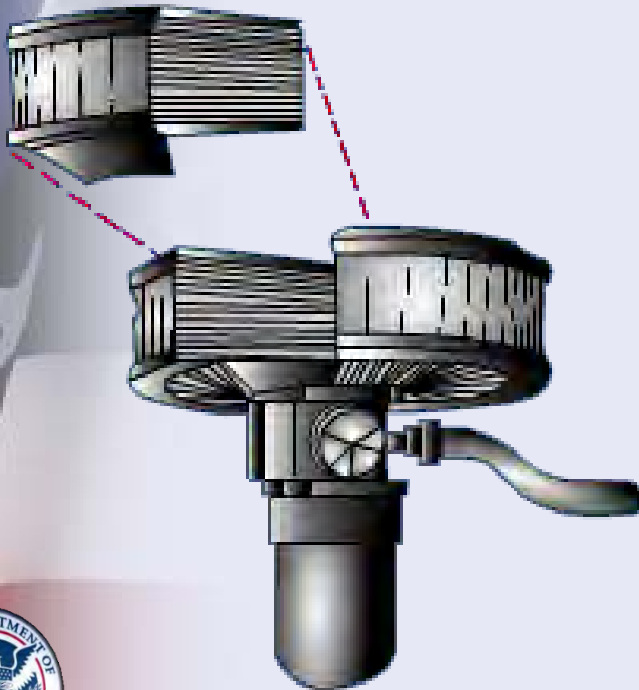



Proper Ventilation

- **Required on boats using gasoline for electrical generation, mechanical power, or propulsion.**
- **Powered ventilation on boats built after 31 July 1980**
- **Natural ventilation for boats built before 1 August 1980**





Proper Ventilation

- Powered ventilation:
- Warning sticker required to be displayed:
- Gasoline vapors can explode. Before starting engine, operate blower at least four minutes and check engine compartment and bilge for gasoline vapors.

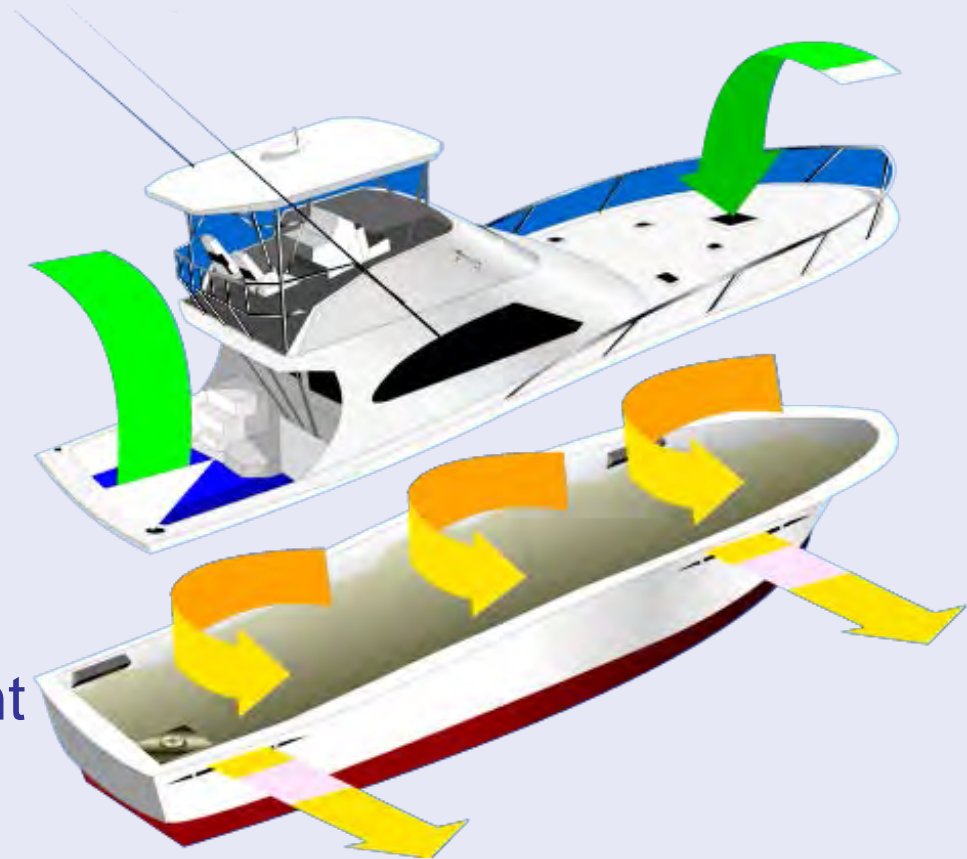



Proper Ventilation

- **Natural ventilation**

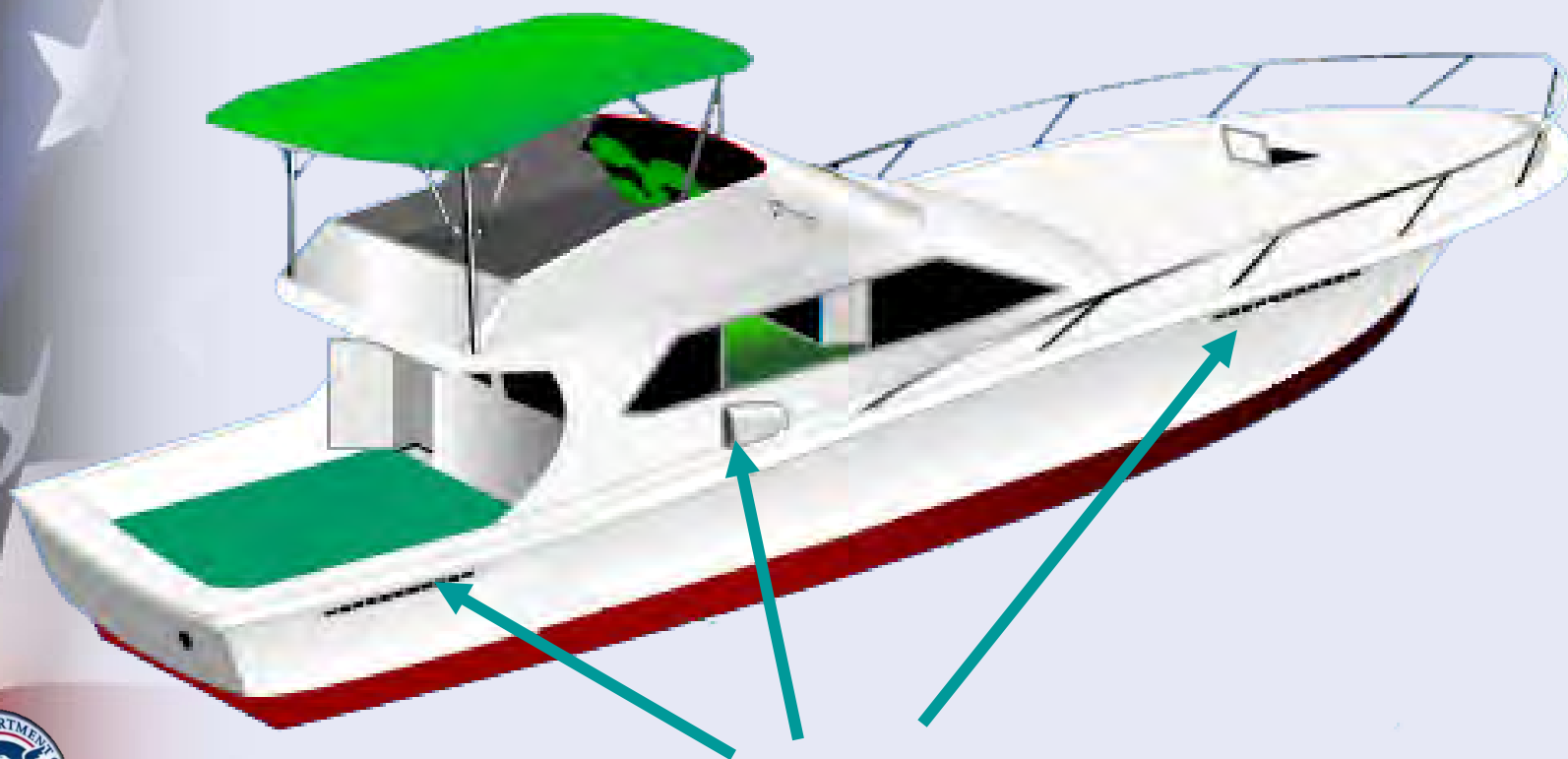

Mufflers





- **Florida requires engine exhaust to be adequately muffled. <90 dBA at 50 ft.**
- **Use of exhaust cut-out prohibited except for races**





Navigation Lights – Power Driven

-  **Sunset to sunrise**
-  **Restricted visibility**
-  **Visible for one or two miles depending on size.**





Navigation Lights - Small Boat

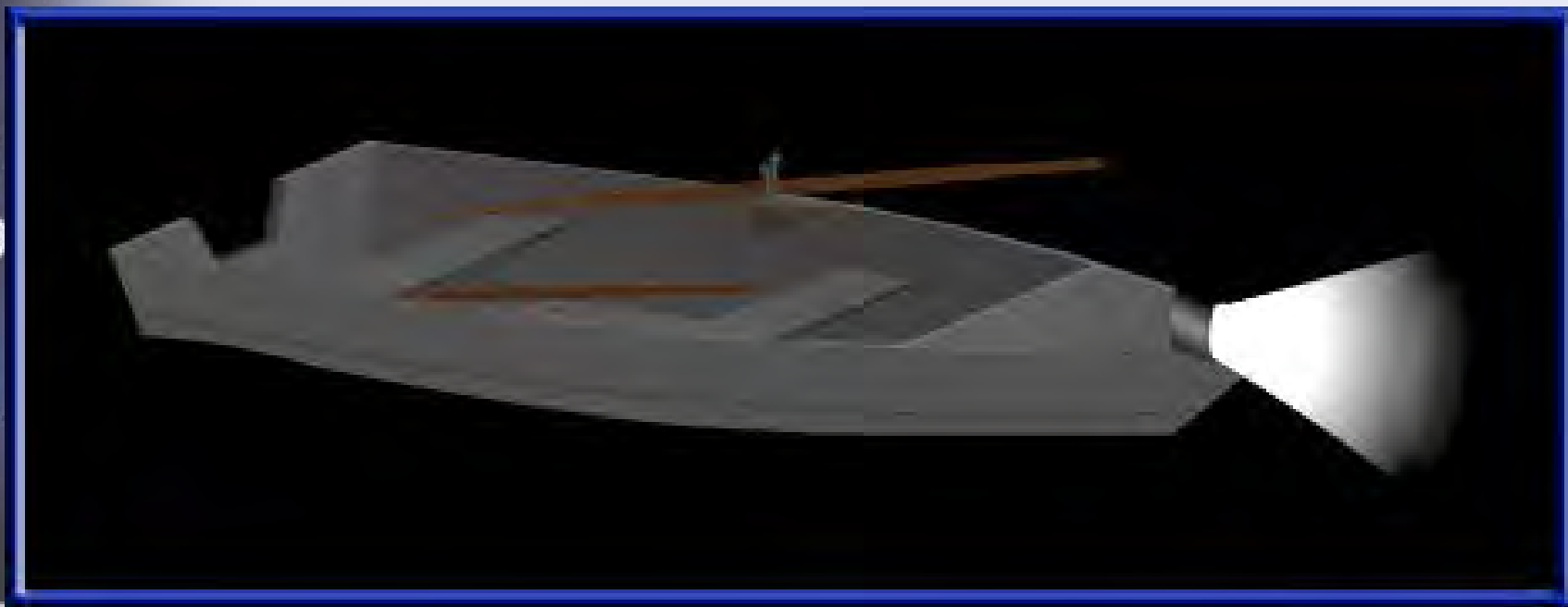

< 7 meters

under oars





Visual Distress Signals

Coastal waters:

- Three hand held combination
- Day/Night red flares



Service life: 42 Months





Or...

- One hand held orange smoke
- Two floating orange smoke
- And one electric SOS light

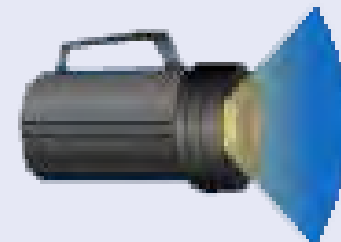
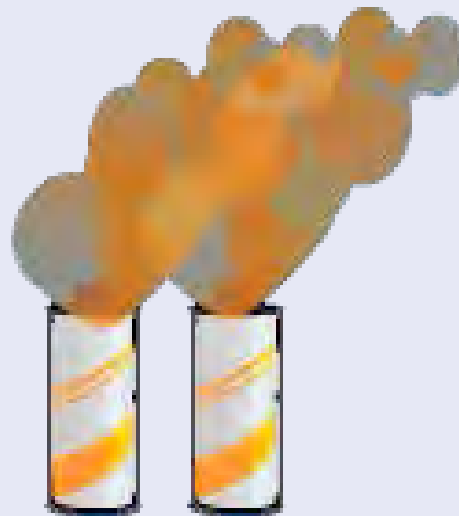

Other VDS

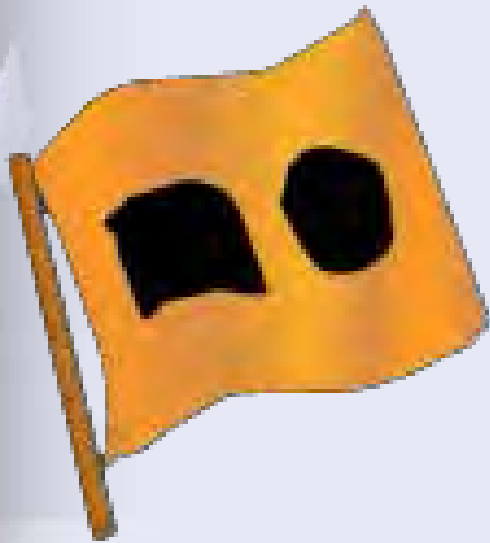

Orange flag
Day signal only

Arm signal not USCG
approved to meet equipment
requirement



Sound Producing Devices

- Boats <20 meters (65 ft.) must carry a whistle or horn



Sound Producing Devices

- Boats 20 meters (65 ft.), or more, also must carry a bell

100 meters or more must also have a gong





Diving/Snorkeling Flags

- **Divers avoid placing in:**
 - Areas already occupied by boaters
 - Narrow channels

Boaters:

Make reasonable effort to stay 300' away in open waters, and 100' away in rivers, inlets, etc. or...

Slow to minimum steerage speed when within 300' in open water and within 100' in rivers, inlets, etc.



**ONLY FLAG
RECOGNIZED IN
FLORIDA**





Other Equipment & Local Regulations

- **State requirements**
 - Registration and licensing
- **Radio station license**
 - Required for foreign ports
- **Local waterways**
 - Specific rules and regulations

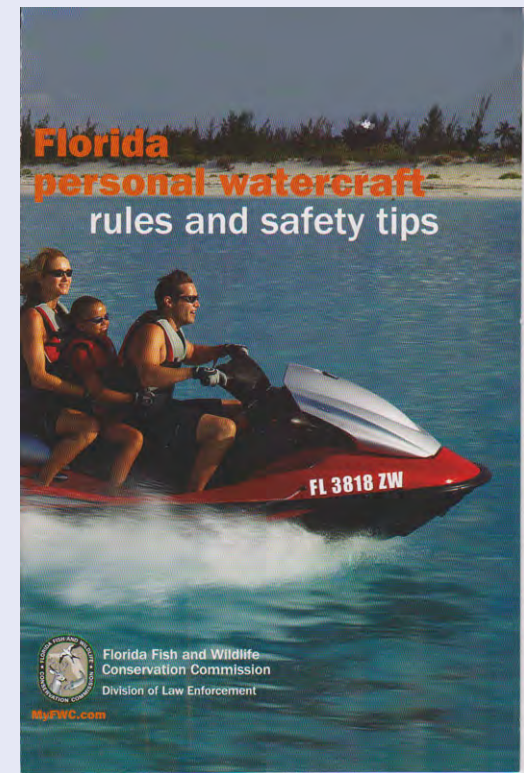



WATER SKIING

All persons engaged in water skiing must wear a USCG approved Type I, II or III PFD.

Vessels towing water skiers must either have an observer or a wide angle rearview mirror.

It is illegal to water ski while intoxicated or under the influence of drugs.

May not occur between one half hour after sunset to one half hour before sunrise.

May not pull skiers close to fixed objects or docks.





Requirements Specific To PWC

- Education requirements
- State certification
- PFD required
- Lanyard required
- No night operation
- No wake jumping close to other vessels

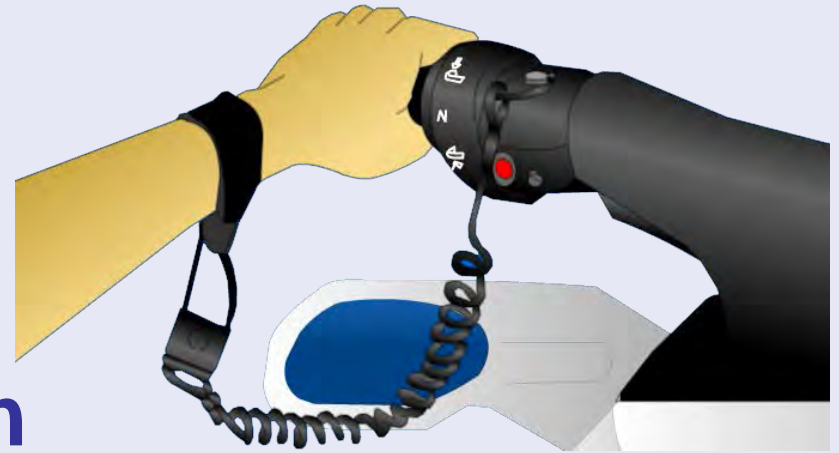



Towing Requirements Boat Or PWC

- No skiing or towing between sunset and sunrise
- PFD required for towed person, cannot be inflatable
- Observer required or in FL a wide angle, approved, mirror

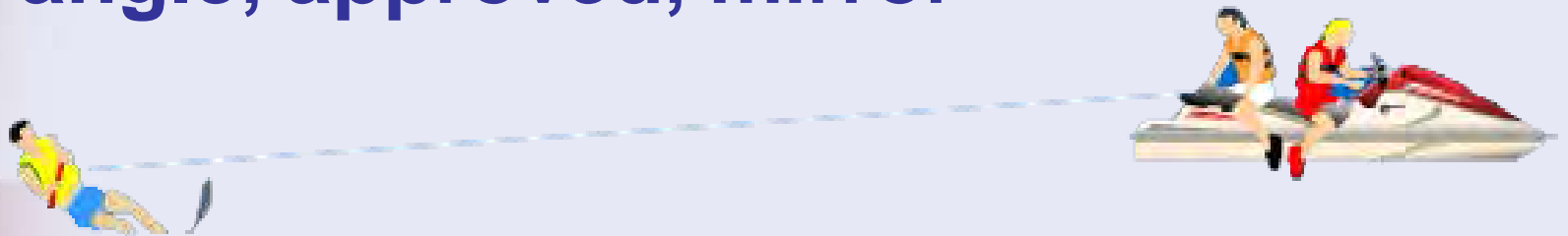



Canoes, Kayaks

- One Type I, II, or III for each person on board. Type IV must be worn.
- Anyone on board < 6yrs must wear Type I, II, or III
- Sound producing device on board
- VDS required in coastal waters and nighttime.
- Operating in limited visibility or nighttime requires white light



Airboat Regulations



- Must be equipped with muffler
- Must have flag displayed 10 feet above lowest part
- Registration numbers placed on both sides of rudder





TRAILERS

- **Must have proper lighting**
- **Must have safety chains (crossed) and tie-down straps**
- **Trailer > 3000 lbs. must have brakes on all wheels**

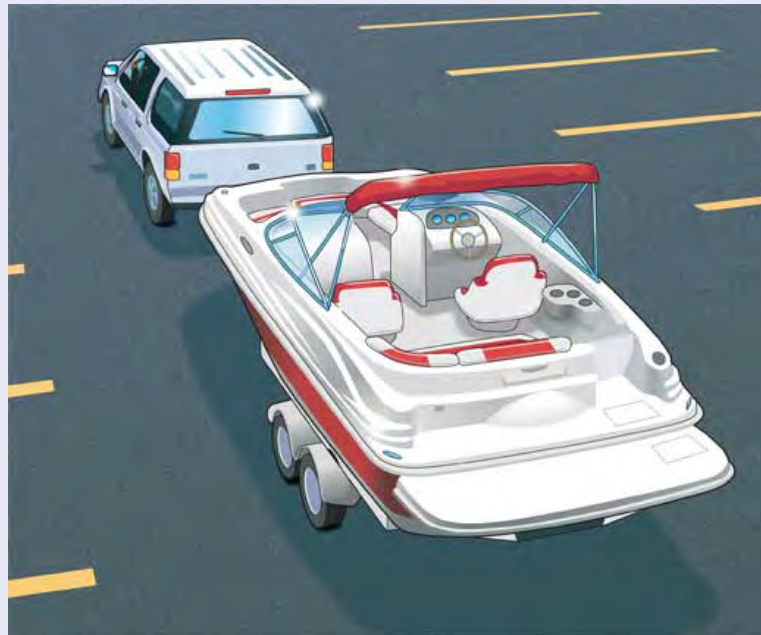



RESTRICTED AREAS

Established by state law and local ordinances.

Illegal to perform any activity posted as prohibited.

Idle speed - minimum speed required to maintain steerage.



Slow speed - no speed greater than that which is reasonable and prudent to avoid disturbing manatees.





RESTRICTED AREAS

MANATEE PROTECTION ZONES

The Florida Manatee Sanctuary Act establishes over 20 manatee protection boat speed zones. It is illegal to violate any of these zones. It is illegal to harass, hunt, capture or kill any marine mammal.



- Do not discard fishing lines or nets in the water
- If you dive or swim near manatees look but don't touch
- Wear polarized sunglasses to help see manatees
- Scan the water near or in front of your boat for water patterns that indicate manatees are nearby



Protect Florida's Sea Grasses



- **Protect the shoreline from erosion, and preserve aquatic vegetation.**
- **Reduce throttle to "no wake" speed when close to a shoreline or in small rivers to help prevent erosion.**
- **Don't operate in shallow water where your prop or pump intake can stir up bottom sediments and destroy aquatic plants.**
- **Drain the bilge and clean the prop before leaving a waterway. Failure to do so may transport plants or animals from one waterway to another and disrupt the natural balance of the environment.**





Waste and Trash

- It is illegal to discharge untreated waste, oil or trash into any Federally controlled or State waters:





Marine Sanitation Devices

- **Type III : porta-potty style**
 - Holding tank only
- **Type I or II: installed on large boats**
 - Chemically treated
 - No discharge within 9 miles of shore in Gulf of Mexico





Marine Sanitation Devices - Type III

All MSD Must Be USCG Approved

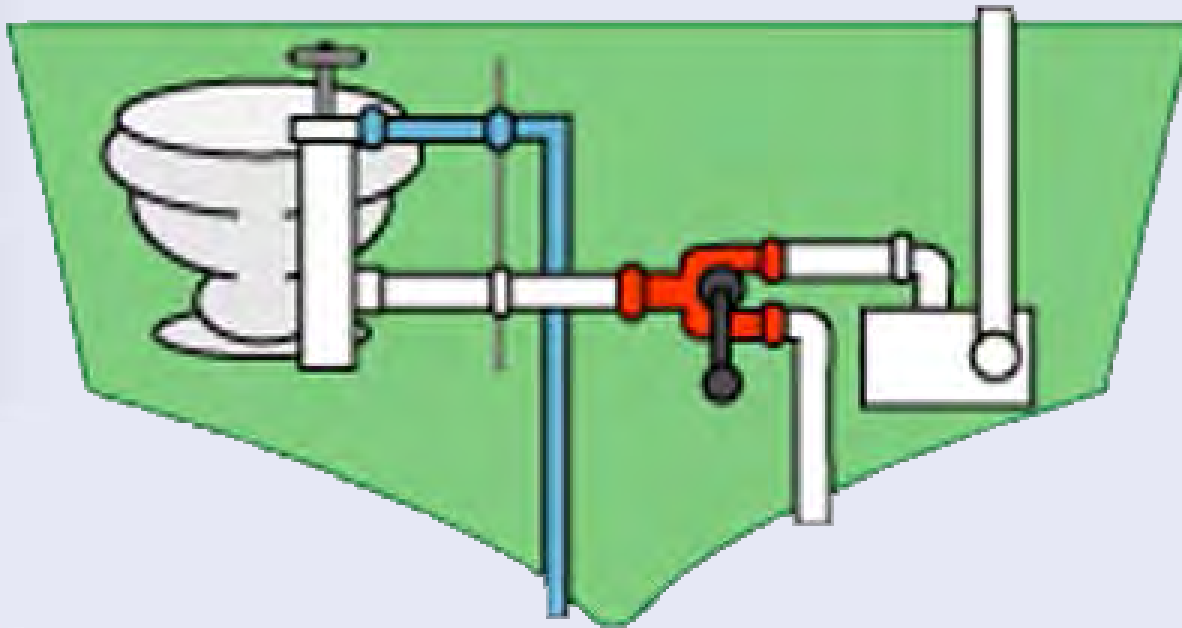



Use Pump Out Stations

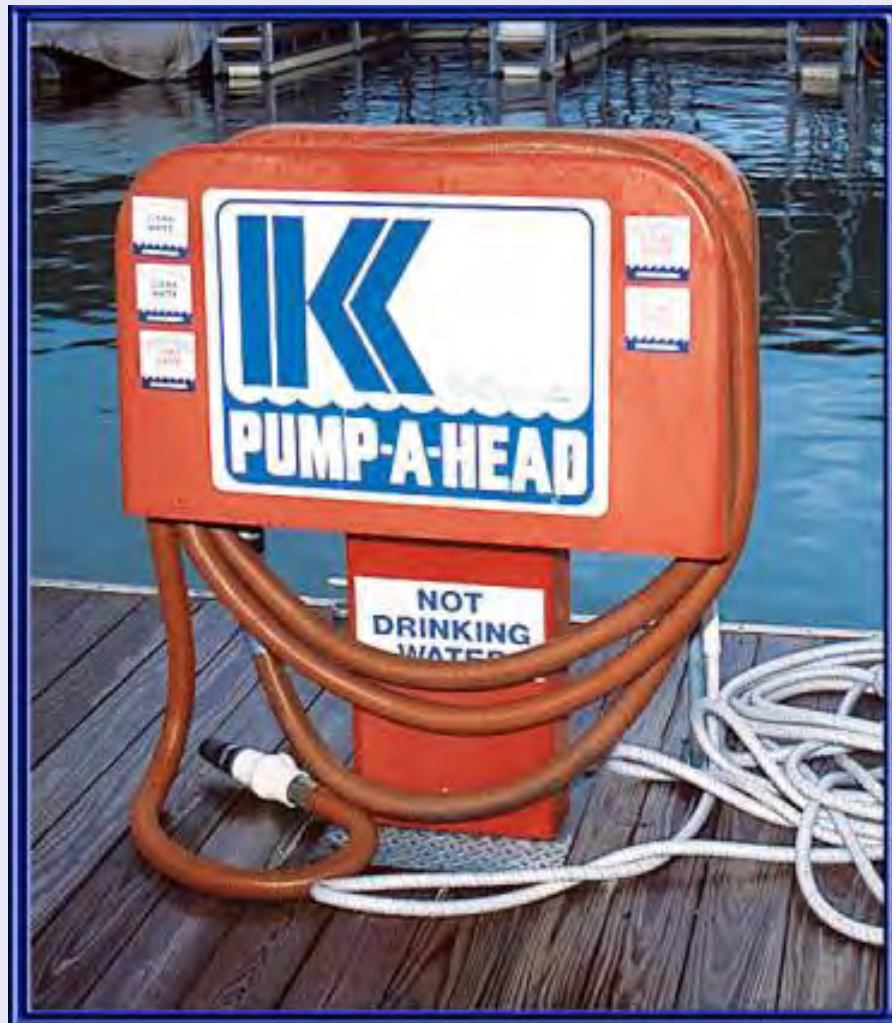



Waste and Trash

Placard required vessels greater than 26 feet





Environmental Protection

- Pollution regulations
 - Placard required vessels greater than 26 feet

It is illegal for any vessel to dump plastic trash anywhere in the ocean or navigable waters of the United States. Annex V of the MARPOL TREATY is a new International Law for a cleaner, safer marine environment. Each violation of these requirements may result in civil penalty up to \$25,000, a fine up to \$50,000, and imprisonment up to 5 years.

**U.S. lakes, rivers, bays, sounds,
and 3 miles from shore**

ILLEGAL TO DUMP:

| | |
|---------|----------|
| Plastic | Garbage |
| Paper | Metal |
| Rags | Crockery |
| Glass | Dunnage |
| Food | |

3 to 12 miles

ILLEGAL TO DUMP:

Plastic
Dunnage (lining & packing
materials that float)

Also, if not ground to
less than one inch:

| | |
|---------|----------|
| Garbage | Metal |
| Paper | Crockery |
| Rags | Food |
| Glass | |

12 to 25 miles

ILLEGAL TO DUMP:

Plastic
Dunnage (lining &
packing materials
that float)

Outside 25 miles

ILLEGAL TO DUMP:

Plastic

State and local regulations may further restrict the disposal of garbage

Working together we can all make a difference!





Waste Management Plan

- Vessels greater than 40 feet with galley and berth must have a written plan posted on board.
- Captain is responsible for implementation





Aquatic Nuisances

- Pump fresh water through engines before leaving the area.
- Drain live-wells, bait buckets, bilge and transom wells.
- Remove water from trailer boats by removing the drain-plug and parking on an incline to facilitate draining.
- Empty water out of kayaks, canoes, rafts, etc.
- Let boat, PWC, trailer and equipment dry for at least 5 days.





Accidents & Casualties

- **Fatal accidents require immediate notification of law enforcement (FWC, Sheriff, or USCG)**
 - Accident reports must be filed within 48 hours
- **If vessel lost or damage over \$2,000**
 - Report must be filed within 10 days
- **Enforcement and penalties**
 - Boat hailed by USCG must stop
 - Civil penalties can be imposed for non-compliance
 - Operator can also be arrested





Homeland Security

- **Stay 100 yds. clear of naval vessels**
- **Be aware of, and avoid, security zones**
- **No stopping or tying up to bridges**
- **Help with America's Waterway Watch**





U.S. Coast Guard

**Can stop and board your vessel for
“safety inspection” at any time.**





End Chapter 5

**BOAT SAFELY AND HAVE FUN
ON THE WATER**

